

# THE LANES

RESIDENCES

## Type A1.1

LEVEL 2

UNIT 3207

---

INTERNAL	115m <sup>2</sup>
EXTERNAL	14m <sup>2</sup>
TOTAL AREA	129m <sup>2</sup>

---

01 ENTRY 02 LIVING 03 DINING  
04 KITCHEN 05 BATHROOM 06 LAUNDRY  
07 LINEN 08 BEDROOM 09 WALK-IN ROBE  
10 ENSUITE 11 BALCONY

---

0m  4m

WEST VILLAGE KEY PLAN

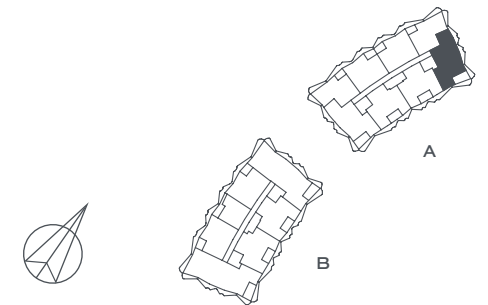

## Sunland Group

Indicative floor plan and artist impression only. Refer to the floor plans contained in the contract of sale for the actual floor plan as variations may apply. All floor areas measured to the centre of external walls and centre line of party walls. All external areas (patio and balconies) are included in the area calculation. External architectural features shown are indicative only. All reasonable care has been taken in the preparation of these floor plans. To the best of our knowledge, no relevant information has been omitted. However Sunland Group Limited and its appointed agents disclaim all liability should any information or matter contained herein differ from the contract of sale or the actual constructed development. Images are illustrative only and all information is correct at the time of printing. © Sunland Group Limited. All rights reserved.

# THE LANES

RESIDENCES

## Type A1.1

LEVEL 3 - 6

UNIT 3307, 3407, 3507, 3607

INTERNAL	115m <sup>2</sup>
EXTERNAL	14m <sup>2</sup>
TOTAL AREA	129m <sup>2</sup>

- 01 ENTRY 02 LIVING 03 DINING  
 04 KITCHEN 05 BATHROOM 06 LAUNDRY  
 07 LINEN 08 BEDROOM 09 WALK-IN ROBE  
 10 ENSUITE 11 BALCONY

0m  4m

### WEST VILLAGE KEY PLAN

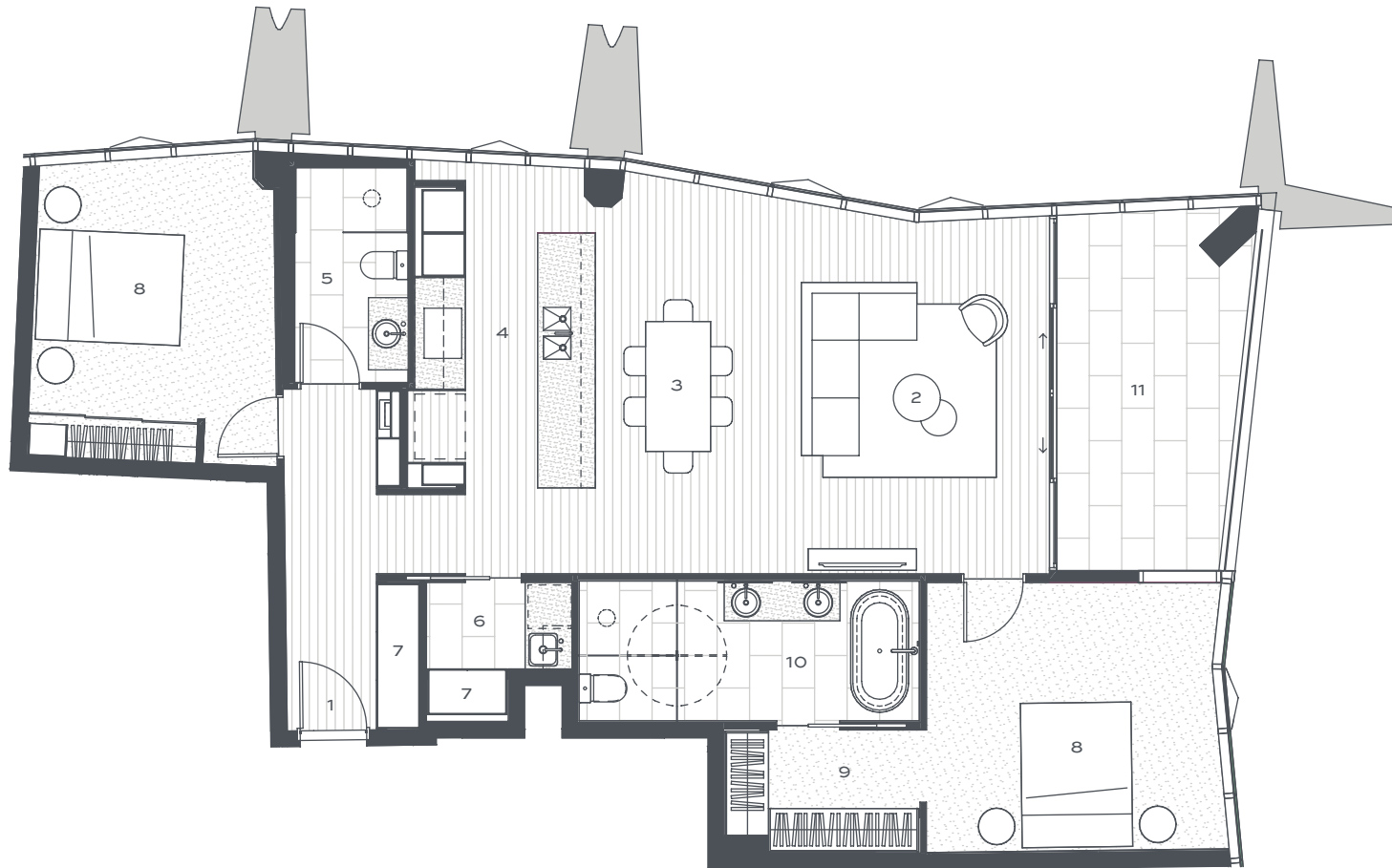
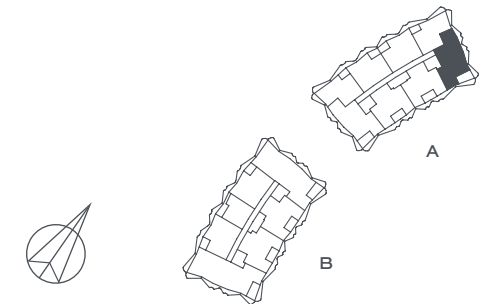

## Sunland Group

Indicative floor plan and artist impression only. Refer to the floor plans contained in the contract of sale for the actual floor plan as variations may apply. All floor areas measured to the centre of external walls and centre line of party walls. All external areas (patio and balconies) are included in the area calculation. External architectural features shown are indicative only. All reasonable care has been taken in the preparation of these floor plans. To the best of our knowledge, no relevant information has been omitted. However Sunland Group Limited and its appointed agents disclaim all liability should any information or matter contained herein differ from the contract of sale or the actual constructed development. Images are illustrative only and all information is correct at the time of printing. © Sunland Group Limited. All rights reserved.

# THE LANES

RESIDENCES

## Type A1

LEVEL 2

UNIT 3202

---

INTERNAL	116m <sup>2</sup>
EXTERNAL	14m <sup>2</sup>
TOTAL AREA	130m <sup>2</sup>

---

01 ENTRY 02 LIVING 03 DINING  
04 KITCHEN 05 BATHROOM 06 LAUNDRY  
07 LINEN 08 BEDROOM 09 WALK-IN ROBE  
10 ENSUITE 11 BALCONY

---

0m  4m

WEST VILLAGE KEY PLAN

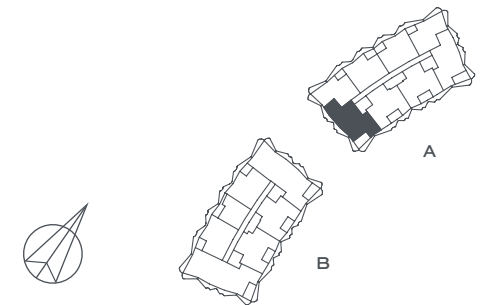

## Sunland Group

Indicative floor plan and artist impression only. Refer to the floor plans contained in the contract of sale for the actual floor plan as variations may apply. All floor areas measured to the centre of external walls and centre line of party walls. All external areas (patio and balconies) are included in the area calculation. External architectural features shown are indicative only. All reasonable care has been taken in the preparation of these floor plans. To the best of our knowledge, no relevant information has been omitted. However Sunland Group Limited and its appointed agents disclaim all liability should any information or matter contained herein differ from the contract of sale or the actual constructed development. Images are illustrative only and all information is correct at the time of printing. © Sunland Group Limited. All rights reserved.

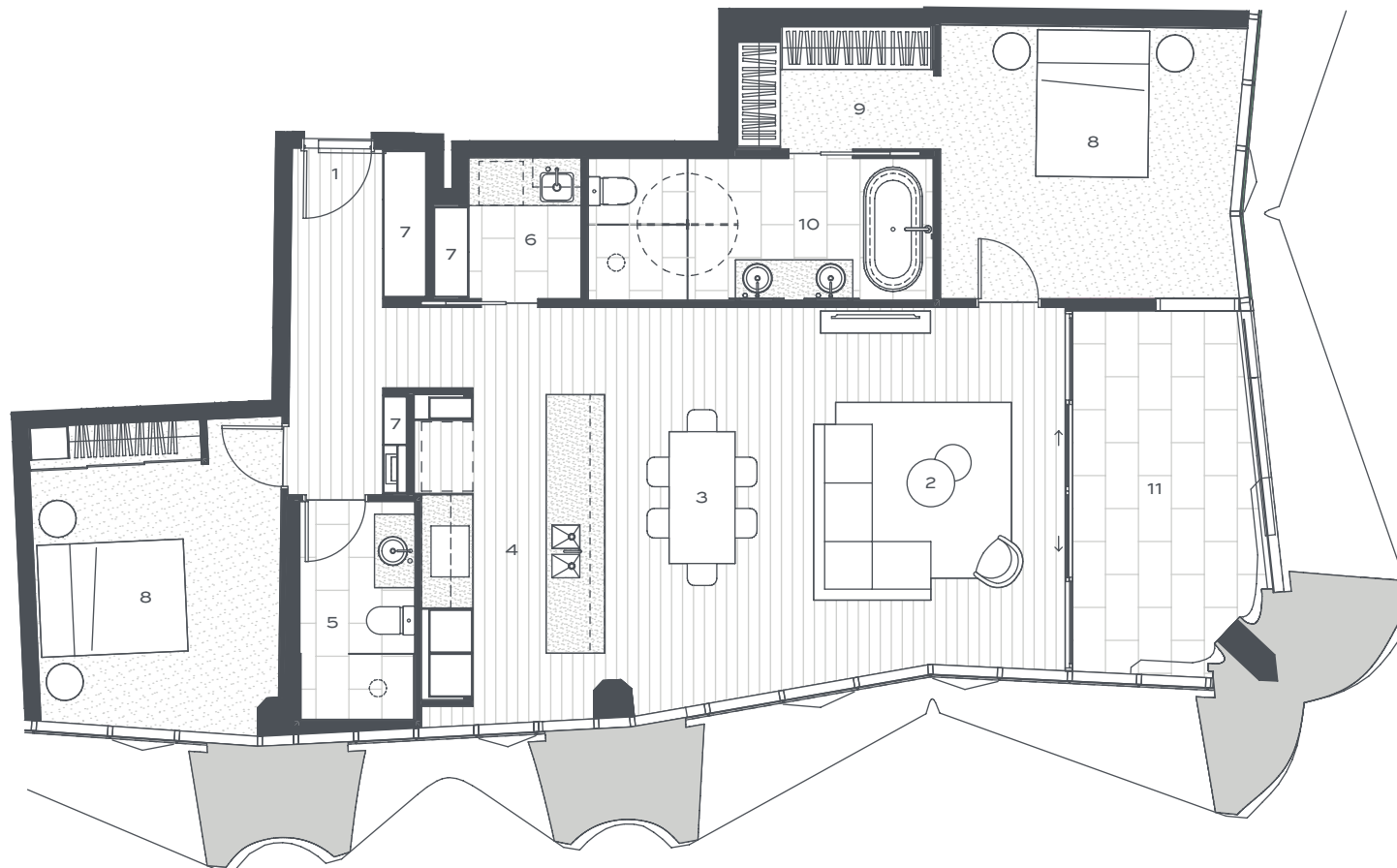

# THE LANES

RESIDENCES

## Type A1

LEVEL 3 - 6

UNIT 3302, 3402, 3502, 3602

---

INTERNAL	116m <sup>2</sup>
EXTERNAL	14m <sup>2</sup>
TOTAL AREA	130m <sup>2</sup>

---

01 ENTRY 02 LIVING 03 DINING  
04 KITCHEN 05 BATHROOM 06 LAUNDRY  
07 LINEN 08 BEDROOM 09 WALK-IN ROBE  
10 ENSUITE 11 BALCONY

---

0m  4m

WEST VILLAGE KEY PLAN

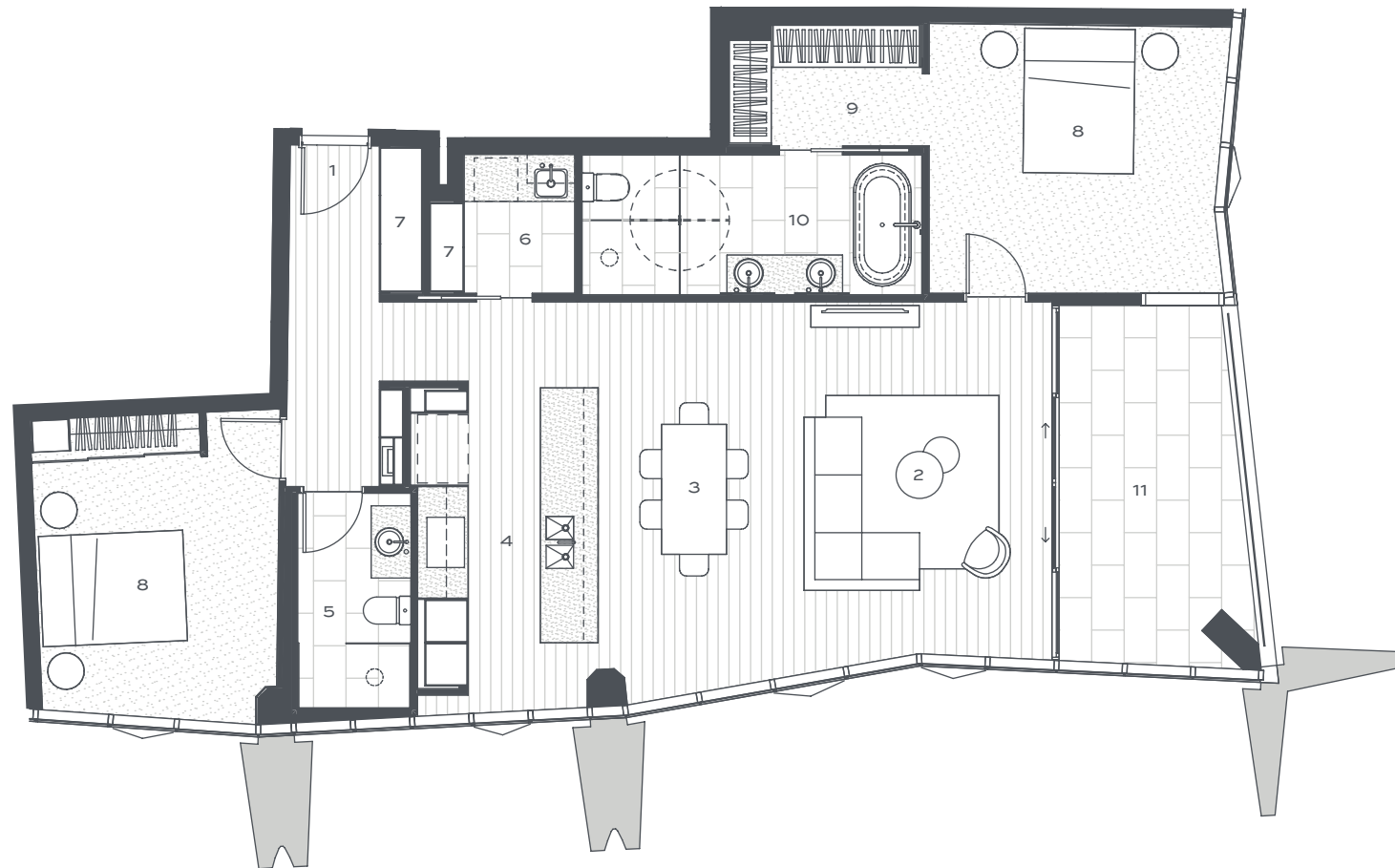
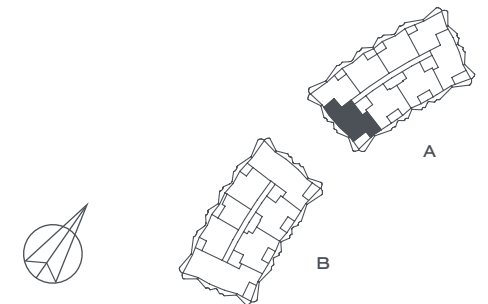

## Sunland Group

Indicative floor plan and artist impression only. Refer to the floor plans contained in the contract of sale for the actual floor plan as variations may apply. All floor areas measured to the centre of external walls and centre line of party walls. All external areas (patio and balconies) are included in the area calculation. External architectural features shown are indicative only. All reasonable care has been taken in the preparation of these floor plans. To the best of our knowledge, no relevant information has been omitted. However Sunland Group Limited and its appointed agents disclaim all liability should any information or matter contained herein differ from the contract of sale or the actual constructed development. Images are illustrative only and all information is correct at the time of printing. © Sunland Group Limited. All rights reserved.

# THE LANES

RESIDENCES

## Type A2.1

LEVEL 1 GROUND

UNIT 3102

---

INTERNAL	114m <sup>2</sup>
EXTERNAL	45m <sup>2</sup>
TOTAL AREA	159m <sup>2</sup>

---

01 ENTRY 02 LIVING 03 DINING  
04 KITCHEN 05 PANTRY 06 BATHROOM  
07 LAUNDRY 08 LINEN 09 BEDROOM  
10 WALK-IN ROBE 11 ENSUITE 12 STUDY  
13 TERRACE 14 COURTYARD

---

0m  4m

WEST VILLAGE KEY PLAN

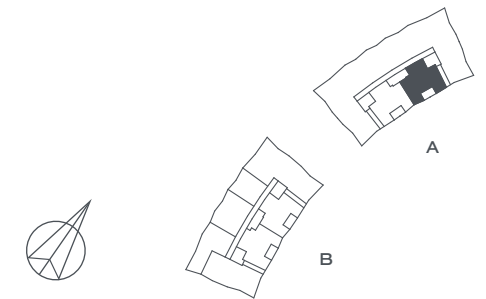

## Sunland Group

Indicative floor plan and artist impression only. Refer to the floor plans contained in the contract of sale for the actual floor plan as variations may apply. All floor areas measured to the centre of external walls and centre line of party walls. All external areas (patio and balconies) are included in the area calculation. External architectural features shown are indicative only. All reasonable care has been taken in the preparation of these floor plans. To the best of our knowledge, no relevant information has been omitted. However Sunland Group Limited and its appointed agents disclaim all liability should any information or matter contained herein differ from the contract of sale or the actual constructed development. Images are illustrative only and all information is correct at the time of printing. © Sunland Group Limited. All rights reserved.

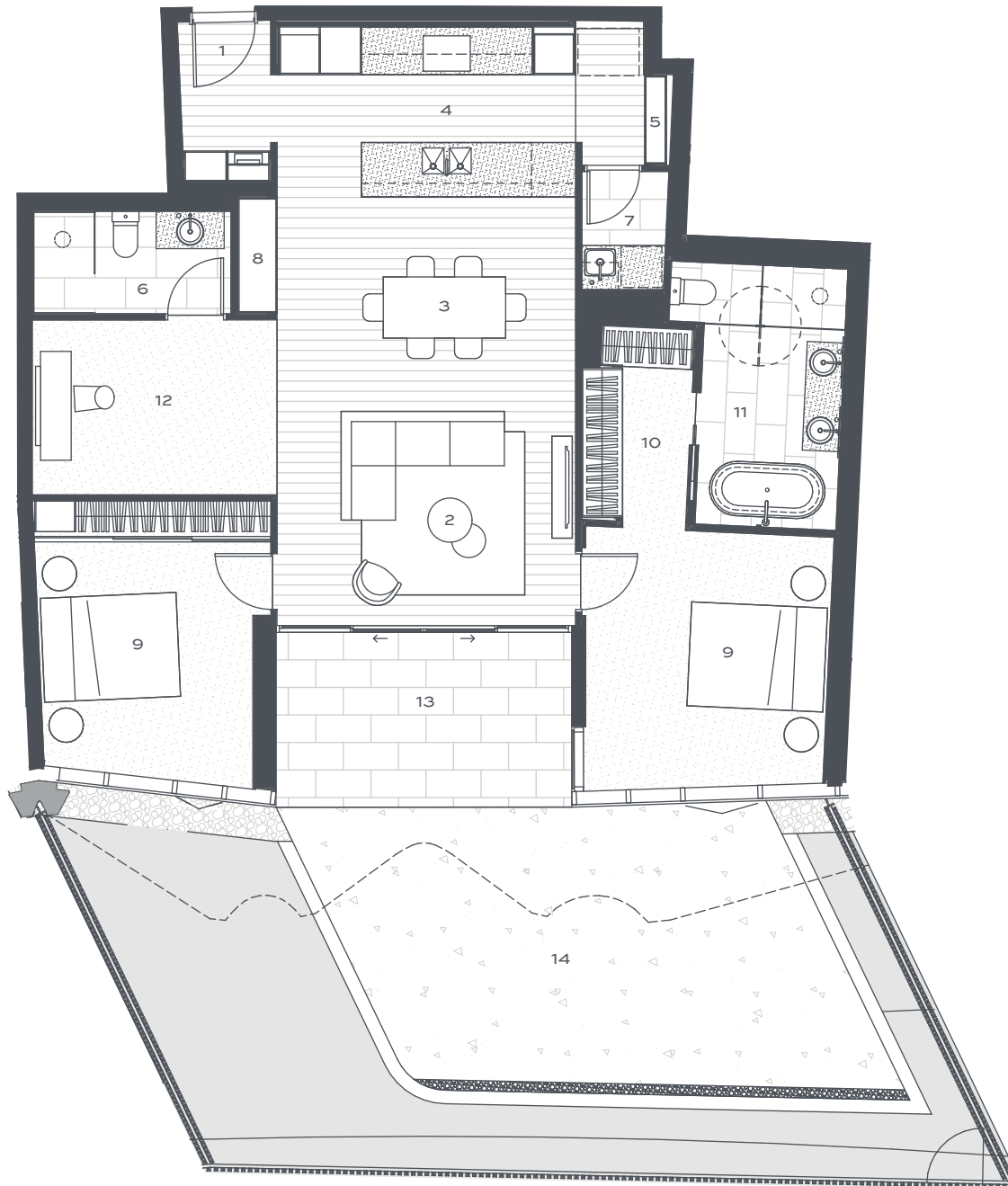

# THE LANES

RESIDENCES

## Type A2.2

LEVEL 1 GROUND

UNIT 3101

---

INTERNAL	110m <sup>2</sup>
EXTERNAL	44m <sup>2</sup>
TOTAL AREA	154m <sup>2</sup>

---

01 ENTRY 02 LIVING 03 DINING  
04 KITCHEN 05 PANTRY 06 BATHROOM  
07 LAUNDRY 08 LINEN 09 BEDROOM  
10 WALK-IN ROBE 11 ENSUITE 12 STUDY  
13 TERRACE 14 COURTYARD

---

0m  4m

WEST VILLAGE KEY PLAN

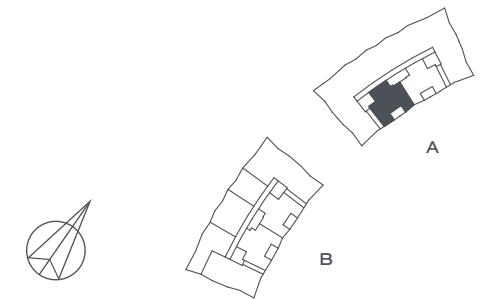

## Sunland Group

Indicative floor plan and artist impression only. Refer to the floor plans contained in the contract of sale for the actual floor plan as variations may apply. All floor areas measured to the centre of external walls and centre line of party walls. All external areas (patio and balconies) are included in the area calculation. External architectural features shown are indicative only. All reasonable care has been taken in the preparation of these floor plans. To the best of our knowledge, no relevant information has been omitted. However Sunland Group Limited and its appointed agents disclaim all liability should any information or matter contained herein differ from the contract of sale or the actual constructed development. Images are illustrative only and all information is correct at the time of printing. © Sunland Group Limited. All rights reserved.

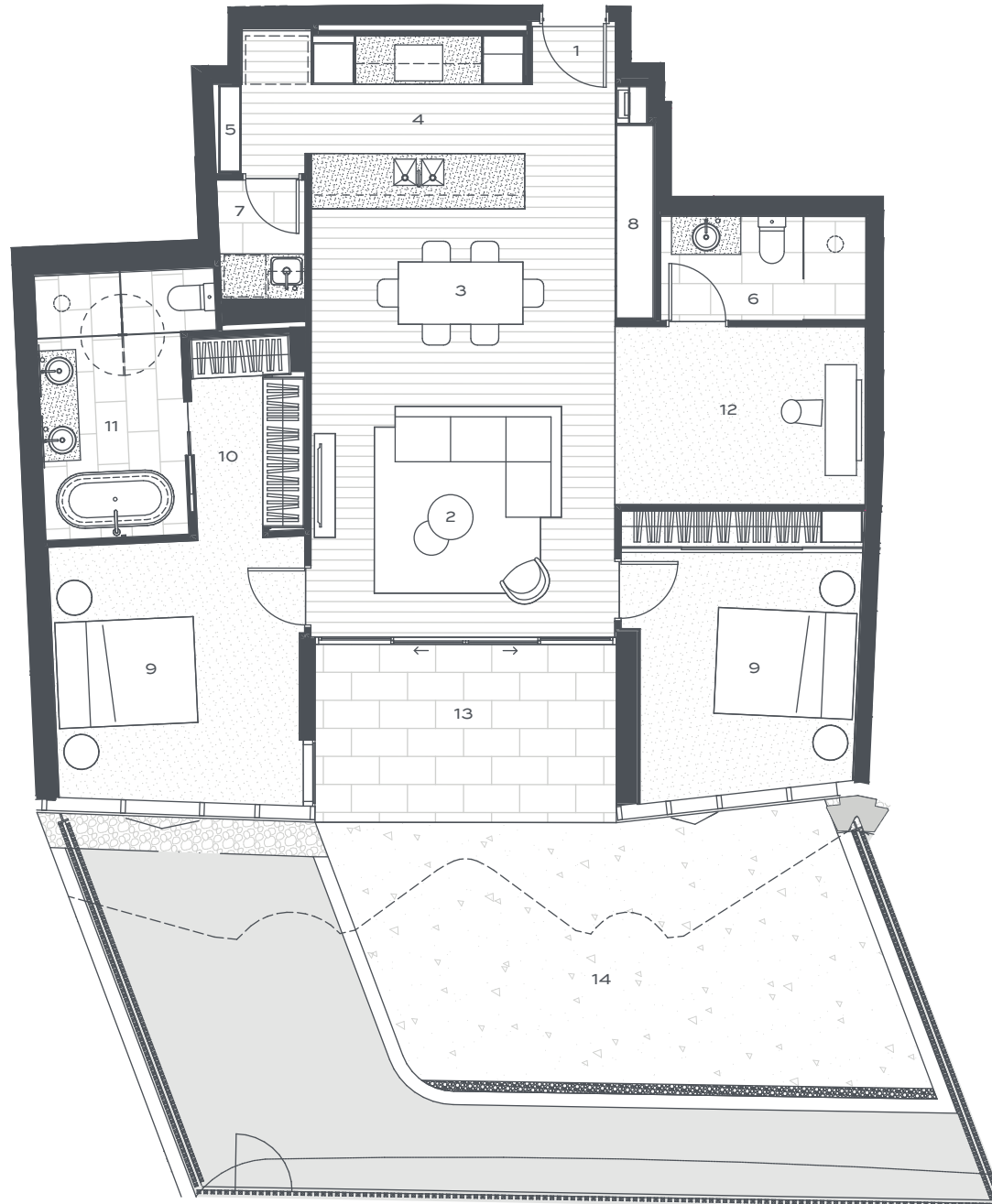

# THE LANES

RESIDENCES

## Type A2.3

LEVEL 2  
UNIT 3208

INTERNAL	109m <sup>2</sup>
EXTERNAL	12m <sup>2</sup>
TOTAL AREA	121m <sup>2</sup>

01 ENTRY 02 LIVING 03 DINING  
04 KITCHEN 05 PANTRY 06 BATHROOM  
07 LAUNDRY 08 LINEN 09 BEDROOM  
10 WALK-IN ROBE 11 ENSUITE 12 STUDY  
13 BALCONY

0m  4m

WEST VILLAGE KEY PLAN

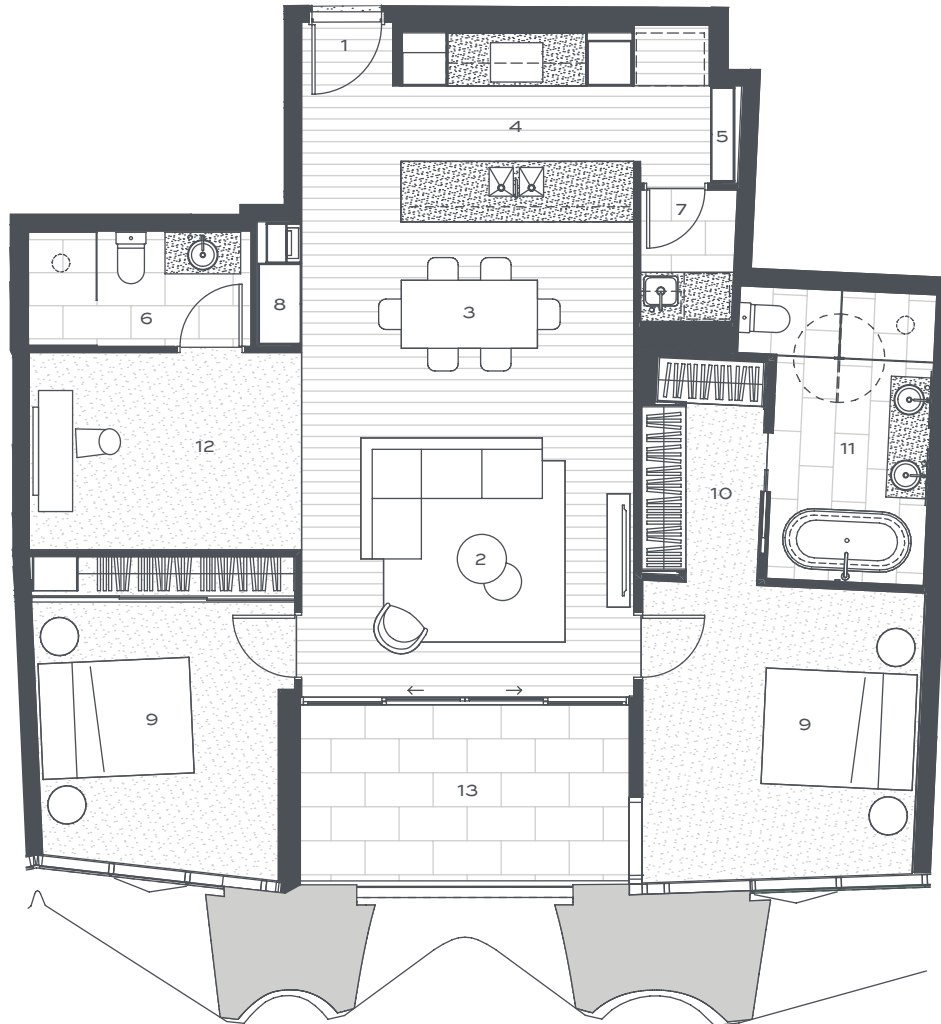
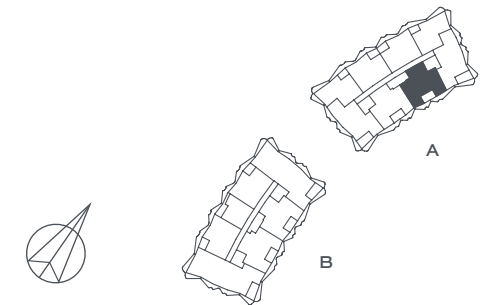

## Sunland Group

Indicative floor plan and artist impression only. Refer to the floor plans contained in the contract of sale for the actual floor plan as variations may apply. All floor areas measured to the centre of external walls and centre line of party walls. All external areas (patio and balconies) are included in the area calculation. External architectural features shown are indicative only. All reasonable care has been taken in the preparation of these floor plans. To the best of our knowledge, no relevant information has been omitted. However Sunland Group Limited and its appointed agents disclaim all liability should any information or matter contained herein differ from the contract of sale or the actual constructed development. Images are illustrative only and all information is correct at the time of printing. © Sunland Group Limited. All rights reserved.

# THE LANES

RESIDENCES

## Type A2.3

LEVEL 3 - 9  
 UNIT 3308, 3408, 3508, 3608, 3708,  
 3808, 3908

INTERNAL	109m <sup>2</sup>
EXTERNAL	12m <sup>2</sup>
TOTAL AREA	121m <sup>2</sup>

01 ENTRY 02 LIVING 03 DINING  
 04 KITCHEN 05 PANTRY 06 BATHROOM  
 07 LAUNDRY 08 LINEN 09 BEDROOM  
 10 WALK-IN ROBE 11 ENSUITE 12 STUDY  
 13 BALCONY

0m  4m

WEST VILLAGE KEY PLAN

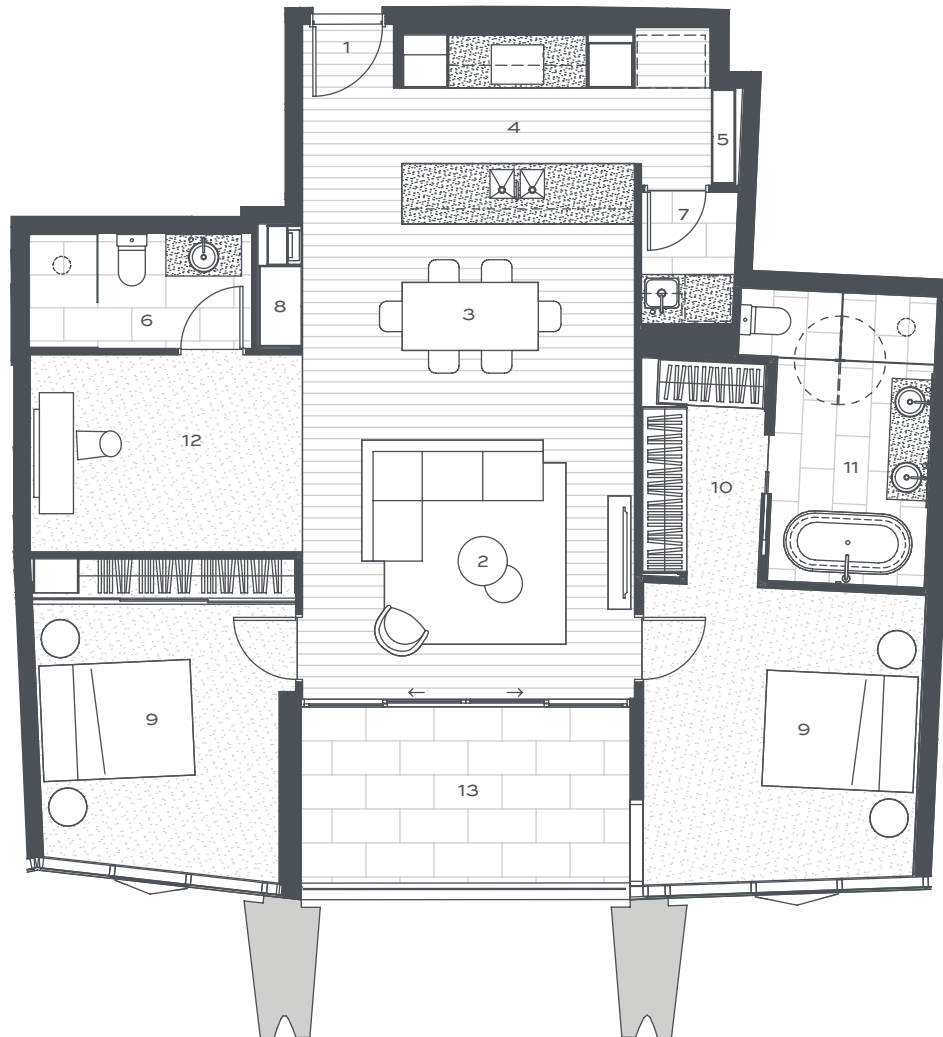
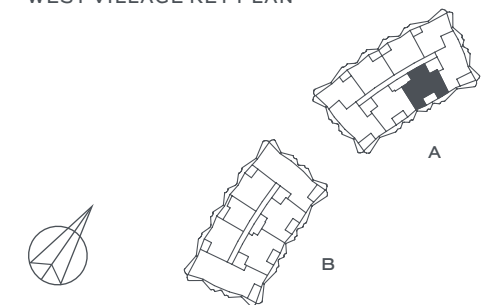

## Sunland Group

Indicative floor plan and artist impression only. Refer to the floor plans contained in the contract of sale for the actual floor plan as variations may apply. All floor areas measured to the centre of external walls and centre line of party walls. All external areas (patio and balconies) are included in the area calculation. External architectural features shown are indicative only. All reasonable care has been taken in the preparation of these floor plans. To the best of our knowledge, no relevant information has been omitted. However Sunland Group Limited and its appointed agents disclaim all liability should any information or matter contained herein differ from the contract of sale or the actual constructed development. Images are illustrative only and all information is correct at the time of printing. © Sunland Group Limited. All rights reserved.



# THE LANES

RESIDENCES

## Type A2.3

LEVEL 10  
UNIT 31008

INTERNAL	109m <sup>2</sup>
EXTERNAL	12m <sup>2</sup>
TOTAL AREA	121m <sup>2</sup>

01 ENTRY 02 LIVING 03 DINING  
04 KITCHEN 05 PANTRY 06 BATHROOM  
07 LAUNDRY 08 LINEN 09 BEDROOM  
10 WALK-IN ROBE 11 ENSUITE 12 STUDY  
13 BALCONY

0m 4m

WEST VILLAGE KEY PLAN

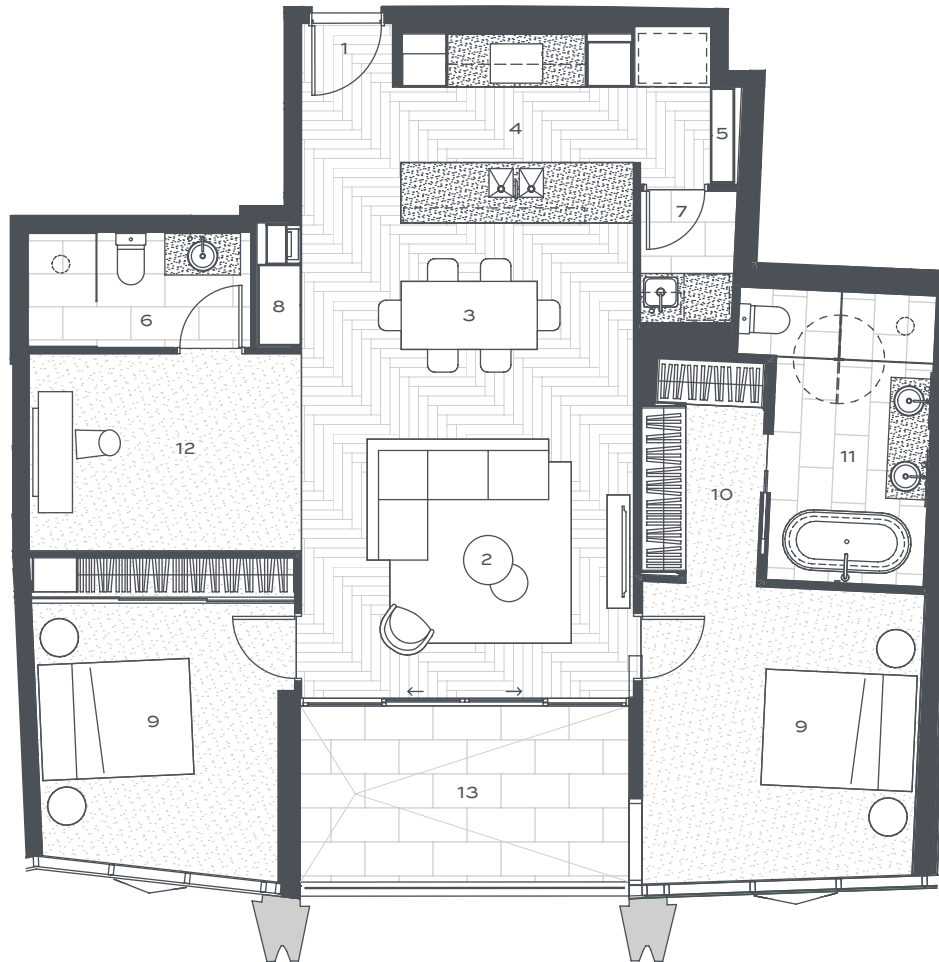
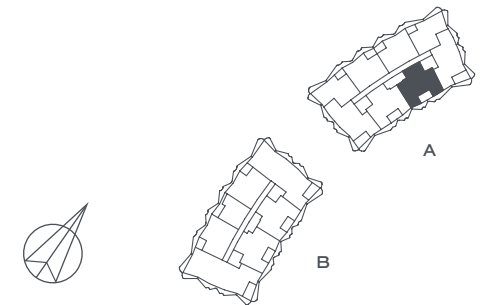

## Sunland Group

Indicative floor plan and artist impression only. Refer to the floor plans contained in the contract of sale for the actual floor plan as variations may apply. All floor areas measured to the centre of external walls and centre line of party walls. All external areas (patio and balconies) are included in the area calculation. External architectural features shown are indicative only. All reasonable care has been taken in the preparation of these floor plans. To the best of our knowledge, no relevant information has been omitted. However Sunland Group Limited and its appointed agents disclaim all liability should any information or matter contained herein differ from the contract of sale or the actual constructed development. Images are illustrative only and all information is correct at the time of printing. © Sunland Group Limited. All rights reserved.

# THE LANES

RESIDENCES

## Type A2

LEVEL 2  
UNIT 3201

---

INTERNAL	110m <sup>2</sup>
EXTERNAL	12m <sup>2</sup>
TOTAL AREA	122m <sup>2</sup>

---

01 ENTRY 02 LIVING 03 DINING  
04 KITCHEN 05 PANTRY 06 BATHROOM  
07 LAUNDRY 08 LINEN 09 BEDROOM  
10 WALK-IN ROBE 11 ENSUITE 12 STUDY  
13 BALCONY

---

0m  4m

WEST VILLAGE KEY PLAN

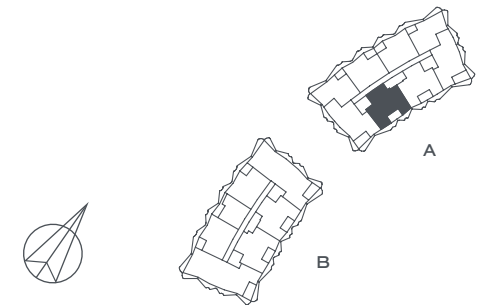

## Sunland Group

Indicative floor plan and artist impression only. Refer to the floor plans contained in the contract of sale for the actual floor plan as variations may apply. All floor areas measured to the centre of external walls and centre line of party walls. All external areas (patio and balconies) are included in the area calculation. External architectural features shown are indicative only. All reasonable care has been taken in the preparation of these floor plans. To the best of our knowledge, no relevant information has been omitted. However Sunland Group Limited and its appointed agents disclaim all liability should any information or matter contained herein differ from the contract of sale or the actual constructed development. Images are illustrative only and all information is correct at the time of printing. © Sunland Group Limited. All rights reserved.

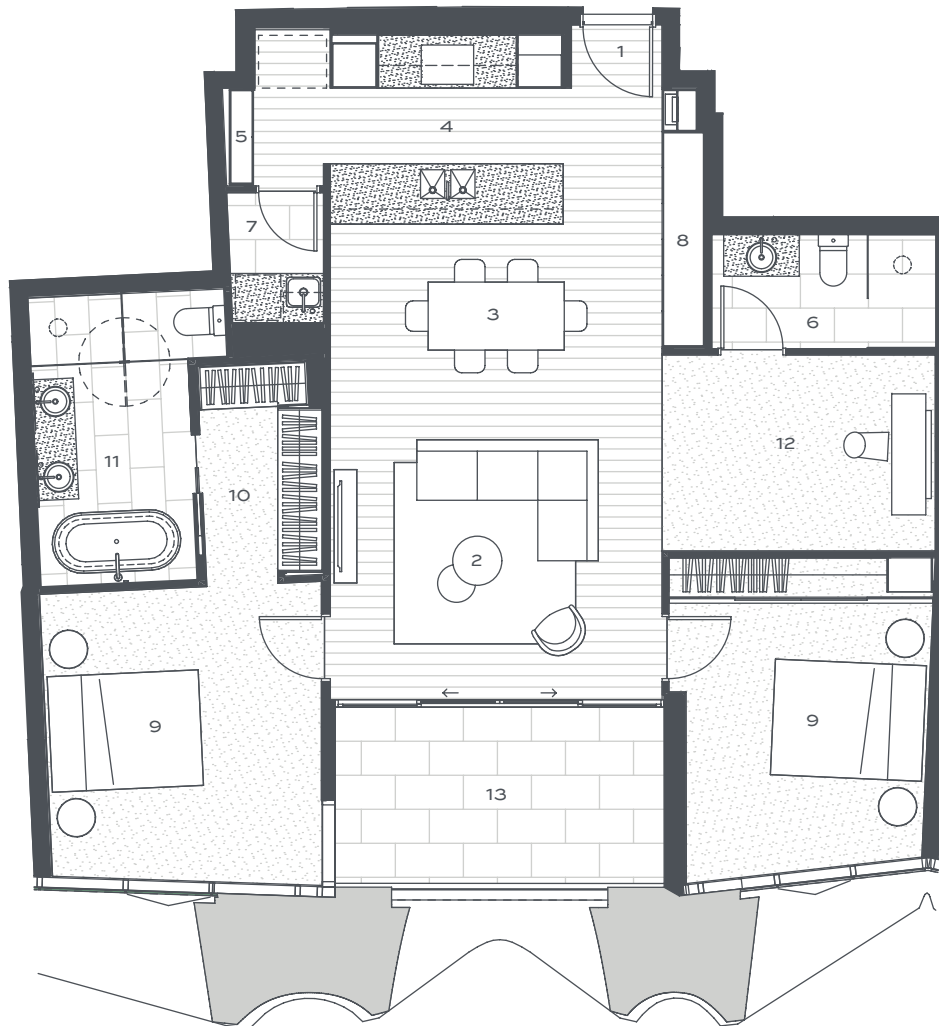

# THE LANES

RESIDENCES

## Type A2

LEVEL 3 - 9  
UNIT 3301, 3401, 3501, 3601, 3701,  
3801, 3901

---

INTERNAL	110m <sup>2</sup>
EXTERNAL	12m <sup>2</sup>
TOTAL AREA	122m <sup>2</sup>

---

01 ENTRY 02 LIVING 03 DINING  
04 KITCHEN 05 PANTRY 06 BATHROOM  
07 LAUNDRY 08 LINEN 09 BEDROOM  
10 WALK-IN ROBE 11 ENSUITE 12 STUDY  
13 BALCONY

---

0m  4m

WEST VILLAGE KEY PLAN

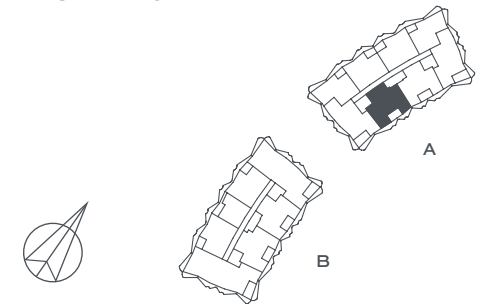

## Sunland Group

Indicative floor plan and artist impression only. Refer to the floor plans contained in the contract of sale for the actual floor plan as variations may apply. All floor areas measured to the centre of external walls and centre line of party walls. All external areas (patio and balconies) are included in the area calculation. External architectural features shown are indicative only. All reasonable care has been taken in the preparation of these floor plans. To the best of our knowledge, no relevant information has been omitted. However Sunland Group Limited and its appointed agents disclaim all liability should any information or matter contained herein differ from the contract of sale or the actual constructed development. Images are illustrative only and all information is correct at the time of printing. © Sunland Group Limited. All rights reserved.

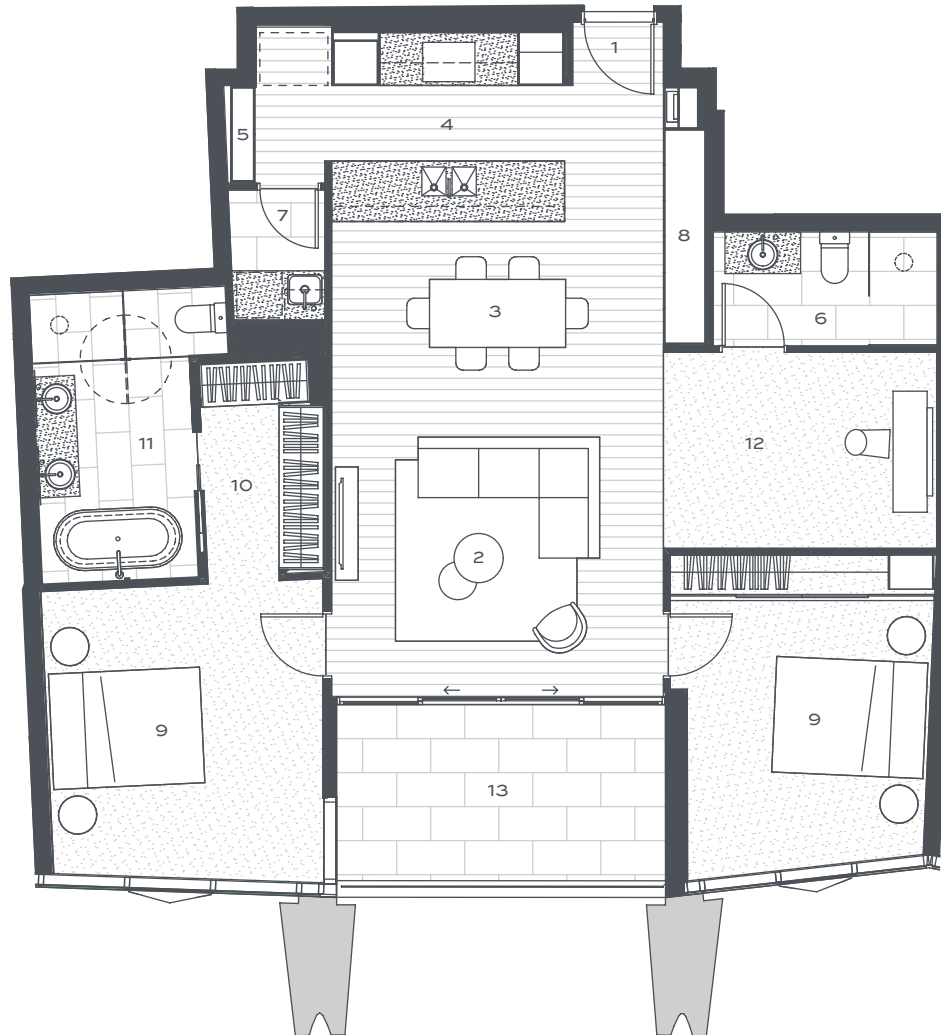

# THE LANES

RESIDENCES

## Type A2

LEVEL 10  
UNIT 31001

---

INTERNAL	110m <sup>2</sup>
EXTERNAL	12m <sup>2</sup>
TOTAL AREA	122m <sup>2</sup>

---

01 ENTRY 02 LIVING 03 DINING  
04 KITCHEN 05 PANTRY 06 BATHROOM  
07 LAUNDRY 08 LINEN 09 BEDROOM  
10 WALK-IN ROBE 11 ENSUITE 12 STUDY  
13 BALCONY

---

0m  4m

WEST VILLAGE KEY PLAN

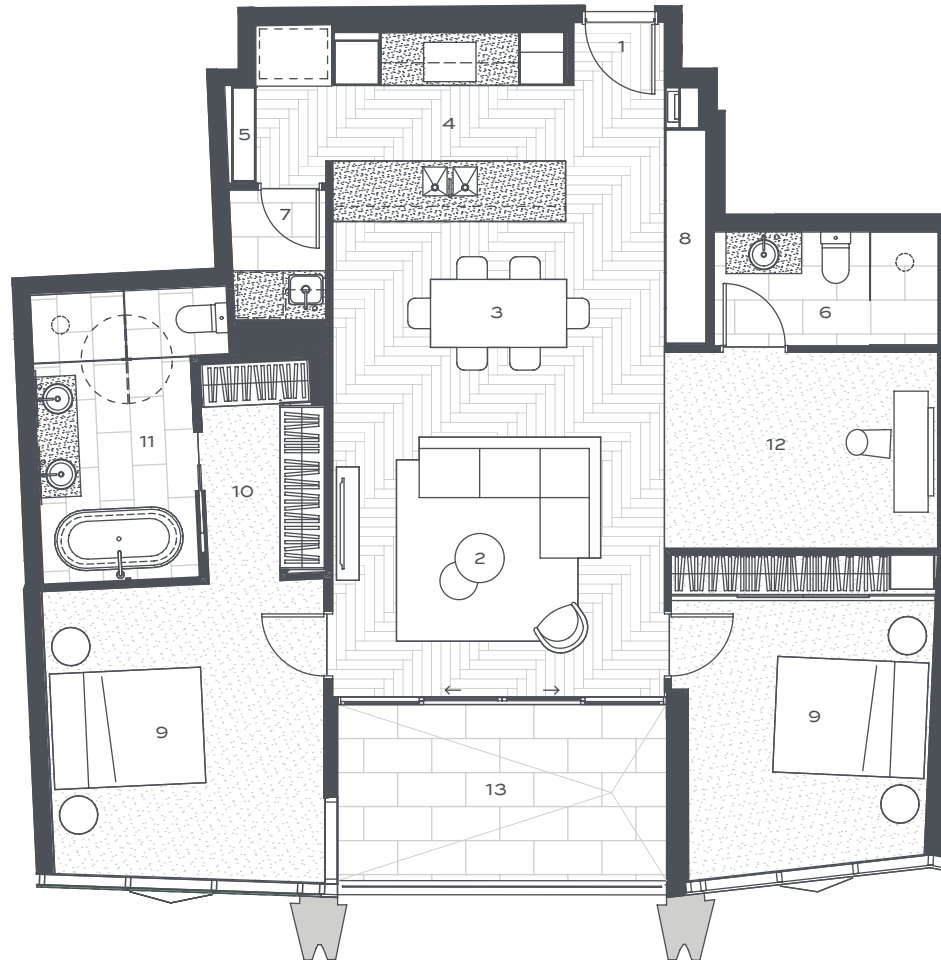
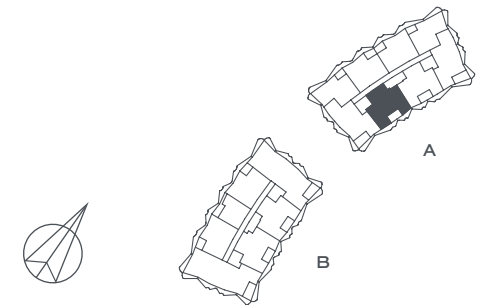

## Sunland Group

Indicative floor plan and artist impression only. Refer to the floor plans contained in the contract of sale for the actual floor plan as variations may apply. All floor areas measured to the centre of external walls and centre line of party walls. All external areas (patio and balconies) are included in the area calculation. External architectural features shown are indicative only. All reasonable care has been taken in the preparation of these floor plans. To the best of our knowledge, no relevant information has been omitted. However Sunland Group Limited and its appointed agents disclaim all liability should any information or matter contained herein differ from the contract of sale or the actual constructed development. Images are illustrative only and all information is correct at the time of printing. © Sunland Group Limited. All rights reserved.

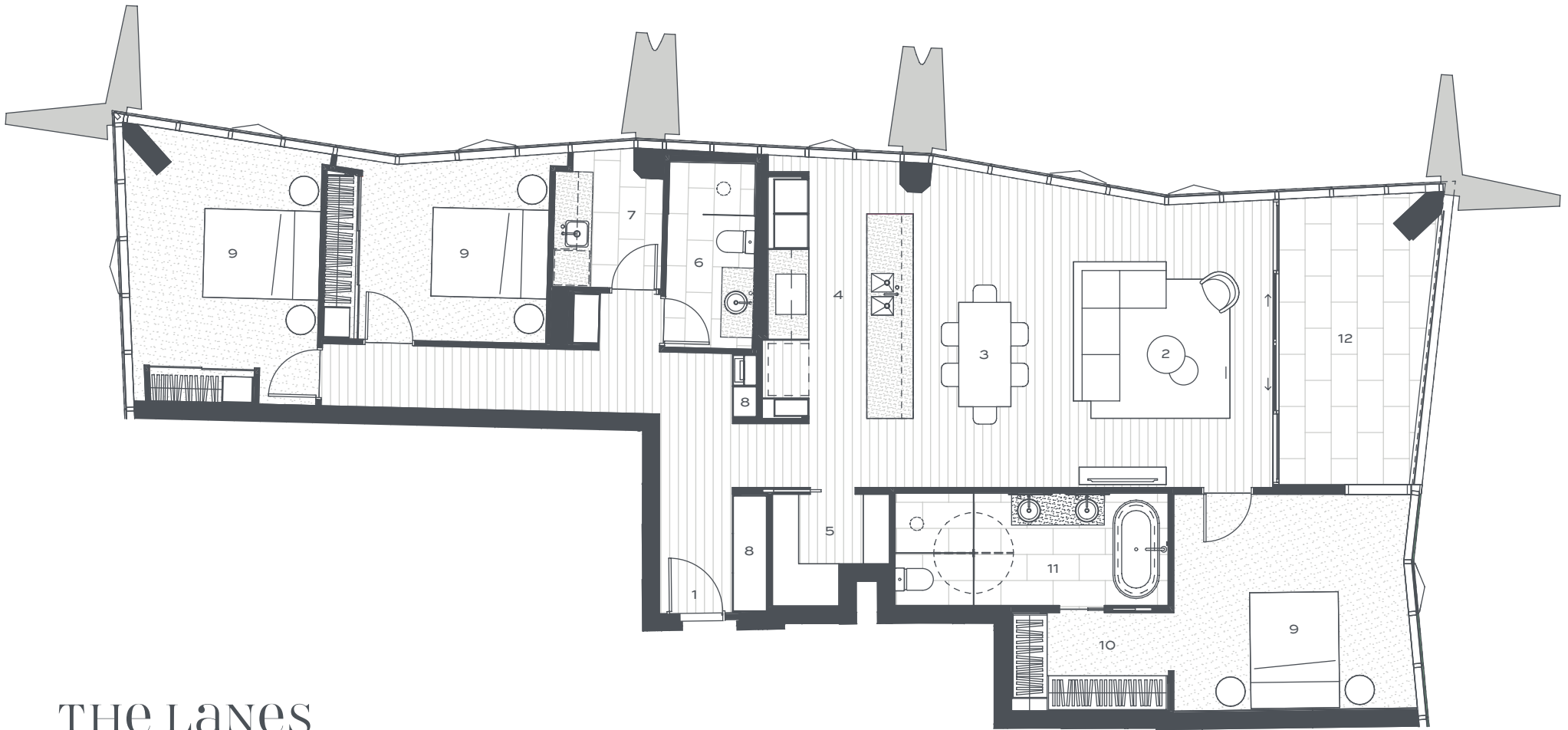

# THE LANES

RESIDENCES

## Type A3.1

LEVEL 7 - 9  
 UNIT 3707, 3807, 3907

INTERNAL	142m <sup>2</sup>
EXTERNAL	14m <sup>2</sup>
TOTAL AREA	156m <sup>2</sup>

0m 4m



WEST VILLAGE KEY PLAN

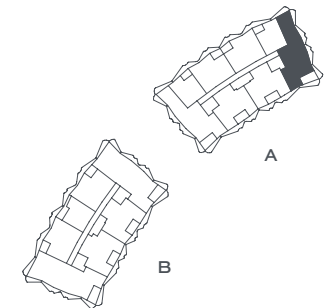

01 ENTRY 02 LIVING 03 DINING 04 KITCHEN 05 PANTRY 06 BATHROOM 07 LAUNDRY 08 LINEN 09 BEDROOM 10 WALK-IN ROBE  
 11 ENSUITE 12 BALCONY

Indicative floor plan and artist impression only. Refer to the floor plans contained in the contract of sale for the actual floor plan as variations may apply. All floor areas measured to the centre of external walls and centre line of party walls. All external areas (patio and balconies) are included in the area calculation. External architectural features shown are indicative only. All reasonable care has been taken in the preparation of these floor plans. To the best of our knowledge, no relevant information has been omitted. However Sunland Group Limited and its appointed agents disclaim all liability should any information or matter contained herein differ from the contract of sale or the actual constructed development. Images are illustrative only and all information is correct at the time of printing. © Sunland Group Limited. All rights reserved.

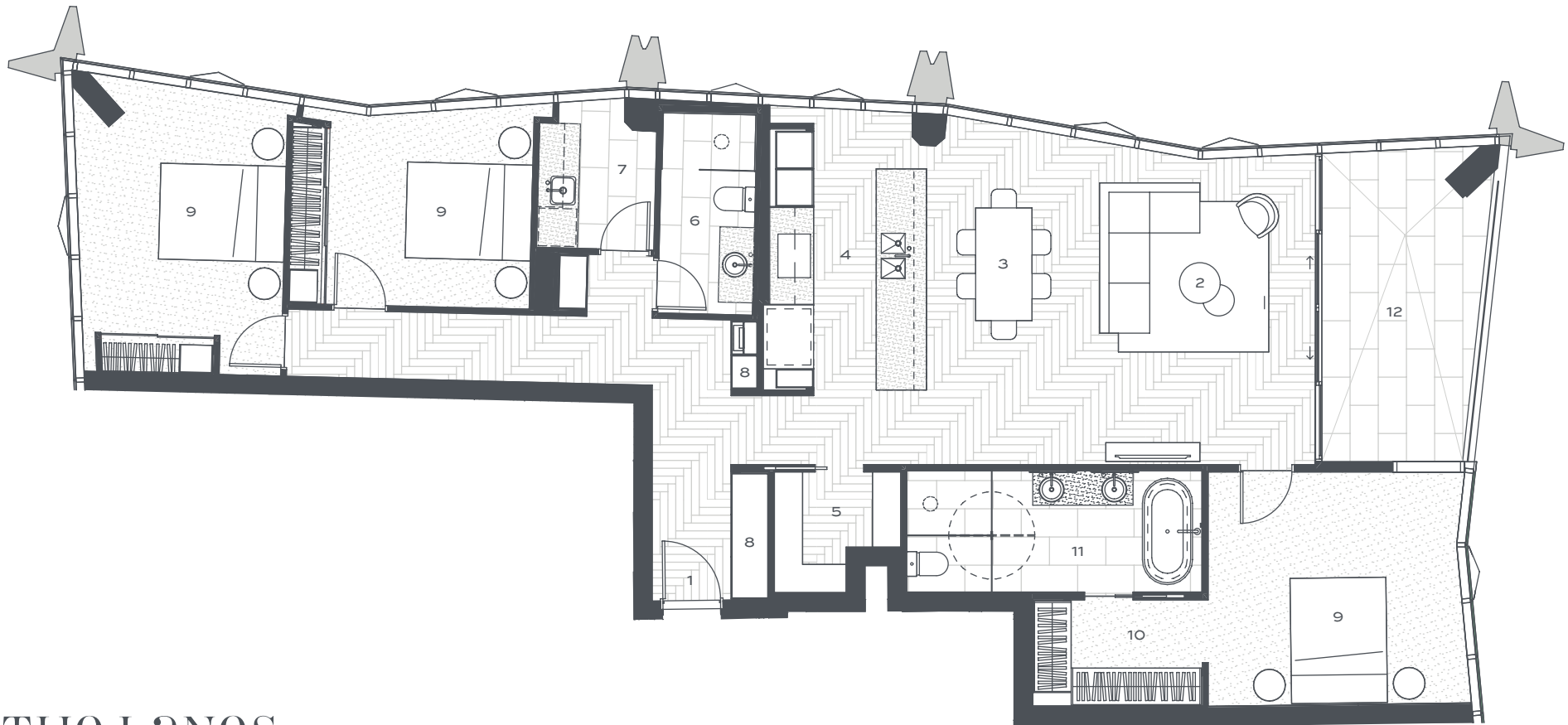

# THE LANES

RESIDENCES

## Type A3.1

LEVEL 10  
UNIT 31007

INTERNAL	142m <sup>2</sup>
EXTERNAL	14m <sup>2</sup>
TOTAL AREA	156m <sup>2</sup>

0m 4m



WEST VILLAGE KEY PLAN

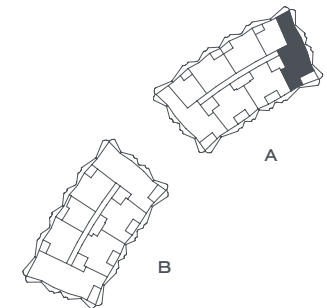

01 ENTRY 02 LIVING 03 DINING 04 KITCHEN 05 PANTRY 06 BATHROOM 07 LAUNDRY 08 LINEN 09 BEDROOM 10 WALK-IN ROBE  
11 ENSUITE 12 BALCONY

Indicative floor plan and artist impression only. Refer to the floor plans contained in the contract of sale for the actual floor plan as variations may apply. All floor areas measured to the centre of external walls and centre line of party walls. All external areas (patio and balconies) are included in the area calculation. External architectural features shown are indicative only. All reasonable care has been taken in the preparation of these floor plans. To the best of our knowledge, no relevant information has been omitted. However Sunland Group Limited and its appointed agents disclaim all liability should any information or matter contained herein differ from the contract of sale or the actual constructed development. Images are illustrative only and all information is correct at the time of printing. © Sunland Group Limited. All rights reserved.

# THE LANES

RESIDENCES

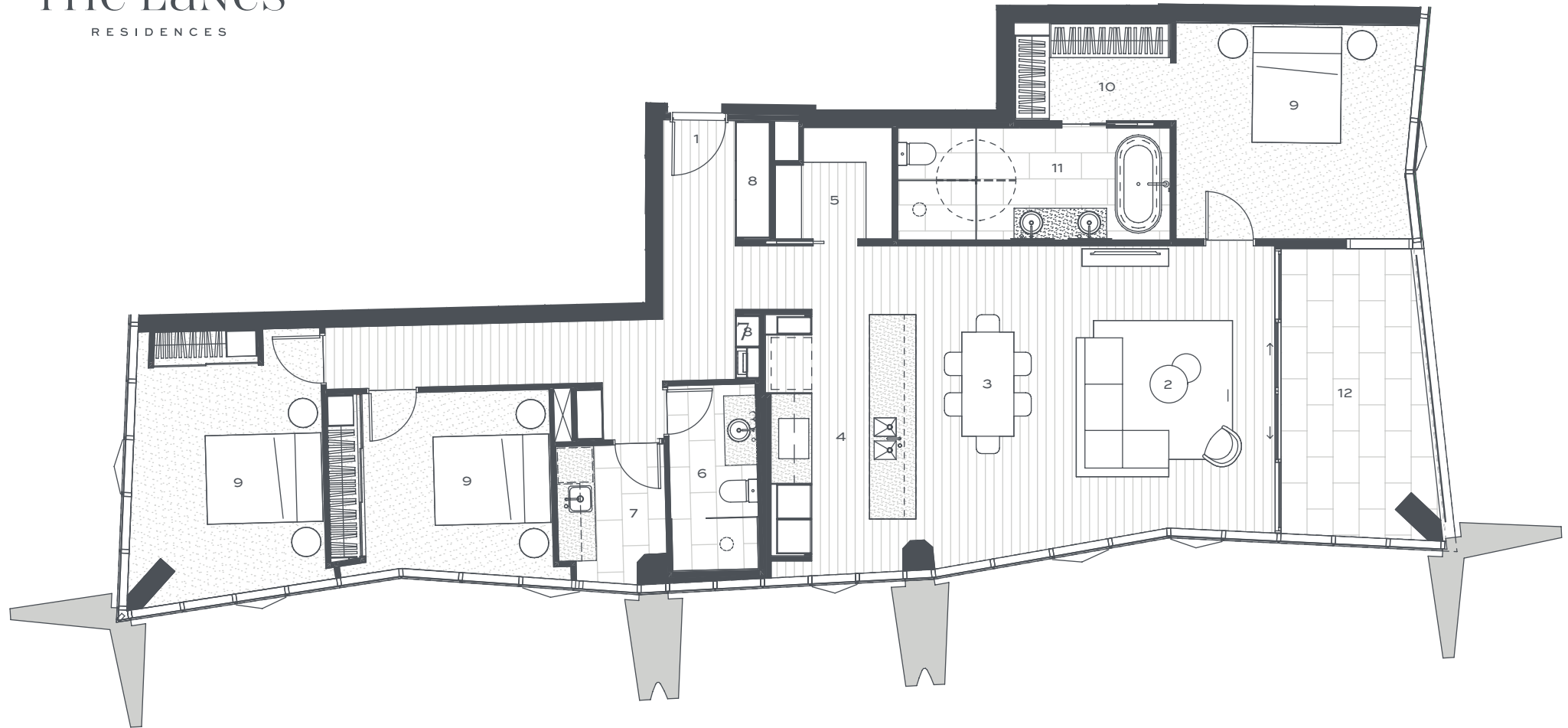

## Type A3

LEVEL 7 - 9  
 UNIT 3702, 3802, 3902

INTERNAL	143m <sup>2</sup>
EXTERNAL	14m <sup>2</sup>
TOTAL AREA	157m <sup>2</sup>

0m 4m



WEST VILLAGE KEY PLAN

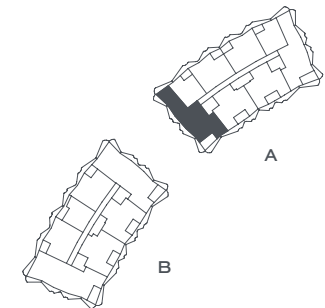

01 ENTRY 02 LIVING 03 DINING 04 KITCHEN 05 PANTRY 06 BATHROOM 07 LAUNDRY 08 LINEN 09 BEDROOM 10 WALK-IN ROBE  
 11 ENSUITE 12 BALCONY

Indicative floor plan and artist impression only. Refer to the floor plans contained in the contract of sale for the actual floor plan as variations may apply. All floor areas measured to the centre of external walls and centre line of party walls. All external areas (patio and balconies) are included in the area calculation. External architectural features shown are indicative only. All reasonable care has been taken in the preparation of these floor plans. To the best of our knowledge, no relevant information has been omitted. However Sunland Group Limited and its appointed agents disclaim all liability should any information or matter contained herein differ from the contract of sale or the actual constructed development. Images are illustrative only and all information is correct at the time of printing. © Sunland Group Limited. All rights reserved.

# THE LANES

RESIDENCES

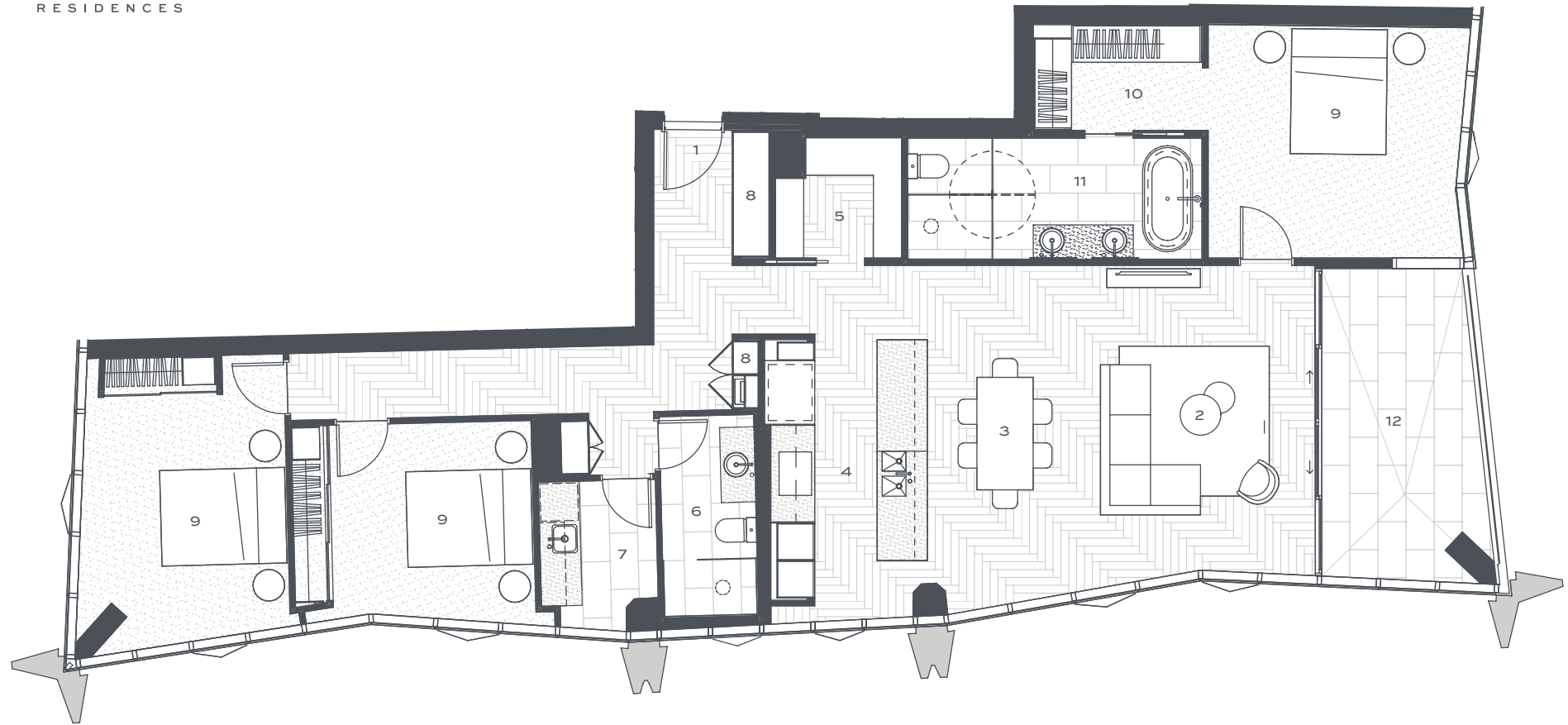

## Type A3

LEVEL 10  
UNIT 31002

INTERNAL	143m <sup>2</sup>
EXTERNAL	14m <sup>2</sup>
TOTAL AREA	157m <sup>2</sup>

0m 4m



WEST VILLAGE KEY PLAN

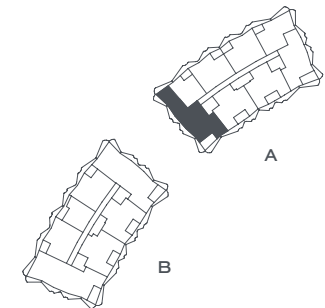

01 ENTRY 02 LIVING 03 DINING 04 KITCHEN 05 PANTRY 06 BATHROOM 07 LAUNDRY 08 LINEN 09 BEDROOM 10 WALK-IN ROBE  
11 ENSUITE 12 BALCONY

Indicative floor plan and artist impression only. Refer to the floor plans contained in the contract of sale for the actual floor plan as variations may apply. All floor areas measured to the centre of external walls and centre line of party walls. All external areas (patio and balconies) are included in the area calculation. External architectural features shown are indicative only. All reasonable care has been taken in the preparation of these floor plans. To the best of our knowledge, no relevant information has been omitted. However Sunland Group Limited and its appointed agents disclaim all liability should any information or matter contained herein differ from the contract of sale or the actual constructed development. Images are illustrative only and all information is correct at the time of printing. © Sunland Group Limited. All rights reserved.



# THE LANES

RESIDENCES

## Type A4.m

LEVEL 2

UNIT 3205

---

INTERNAL	95m <sup>2</sup>
EXTERNAL	8m <sup>2</sup>
TOTAL AREA	103m <sup>2</sup>

---

01 ENTRY 02 LIVING 03 DINING  
04 KITCHEN 05 BATHROOM 06 LAUNDRY  
07 LINEN 08 BEDROOM 09 WALK-IN ROBE  
10 ENSUITE 11 STUDY 12 BALCONY

---

0m  4m

### WEST VILLAGE KEY PLAN

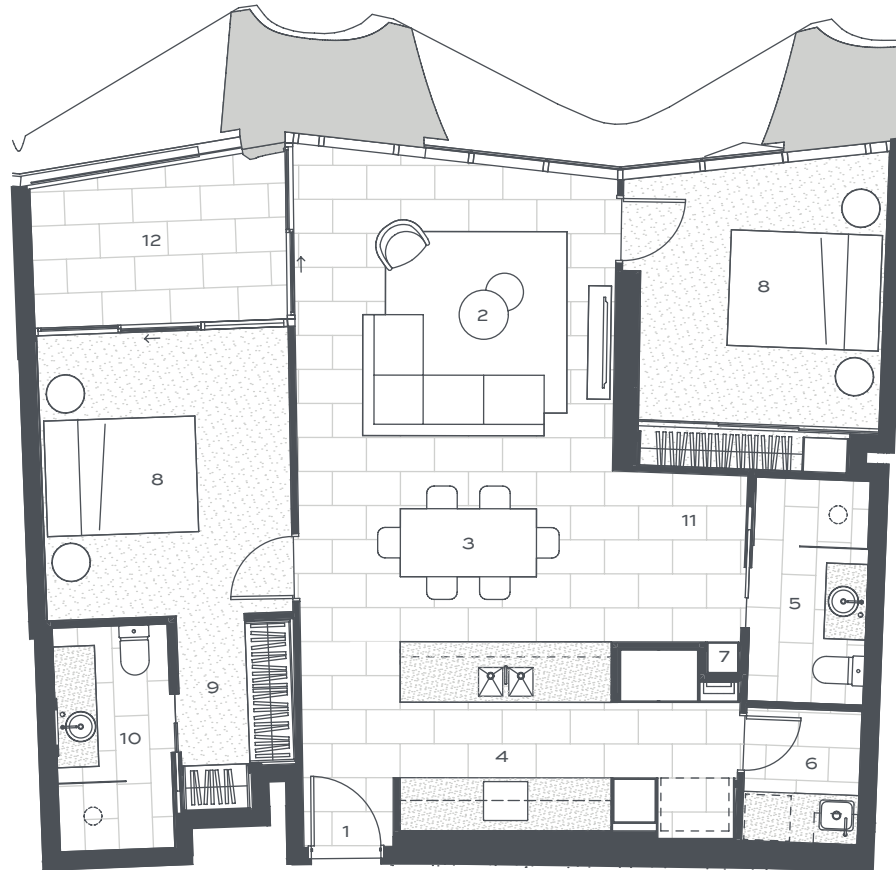
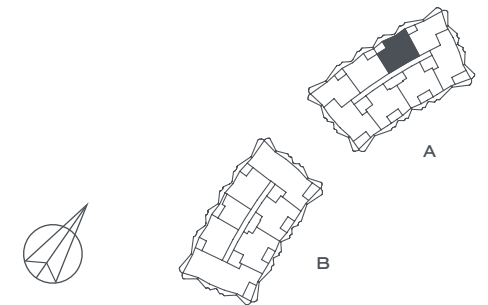

## Sunland Group

Indicative floor plan and artist impression only. Refer to the floor plans contained in the contract of sale for the actual floor plan as variations may apply. All floor areas measured to the centre of external walls and centre line of party walls. All external areas (patio and balconies) are included in the area calculation. External architectural features shown are indicative only. All reasonable care has been taken in the preparation of these floor plans. To the best of our knowledge, no relevant information has been omitted. However Sunland Group Limited and its appointed agents disclaim all liability should any information or matter contained herein differ from the contract of sale or the actual constructed development. Images are illustrative only and all information is correct at the time of printing. © Sunland Group Limited. All rights reserved.

# THE LANES

RESIDENCES

## Type A4.m

LEVEL 3 - 9  
UNIT 3305, 3405, 3505, 3605, 3705,  
3805, 3905

---

INTERNAL	95m <sup>2</sup>
EXTERNAL	8m <sup>2</sup>
TOTAL AREA	103m <sup>2</sup>

---

01 ENTRY 02 LIVING 03 DINING  
04 KITCHEN 05 BATHROOM 06 LAUNDRY  
07 LINEN 08 BEDROOM 09 WALK-IN ROBE  
10 ENSUITE 11 STUDY 12 BALCONY

---

0m  4m

WEST VILLAGE KEY PLAN

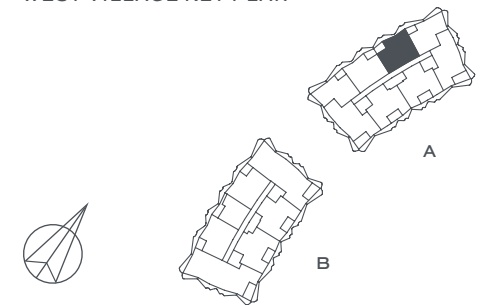

## Sunland Group

Indicative floor plan and artist impression only. Refer to the floor plans contained in the contract of sale for the actual floor plan as variations may apply. All floor areas measured to the centre of external walls and centre line of party walls. All external areas (patio and balconies) are included in the area calculation. External architectural features shown are indicative only. All reasonable care has been taken in the preparation of these floor plans. To the best of our knowledge, no relevant information has been omitted. However Sunland Group Limited and its appointed agents disclaim all liability should any information or matter contained herein differ from the contract of sale or the actual constructed development. Images are illustrative only and all information is correct at the time of printing. © Sunland Group Limited. All rights reserved.

# THE LANES

RESIDENCES

## Type A4.m

LEVEL 10

UNIT 31005

---

INTERNAL	95m <sup>2</sup>
EXTERNAL	8m <sup>2</sup>
TOTAL AREA	103m <sup>2</sup>

---

01 ENTRY 02 LIVING 03 DINING  
04 KITCHEN 05 BATHROOM 06 LAUNDRY  
07 LINEN 08 BEDROOM 09 WALK-IN ROBE  
10 ENSUITE 11 STUDY 12 BALCONY

---

0m  4m

WEST VILLAGE KEY PLAN

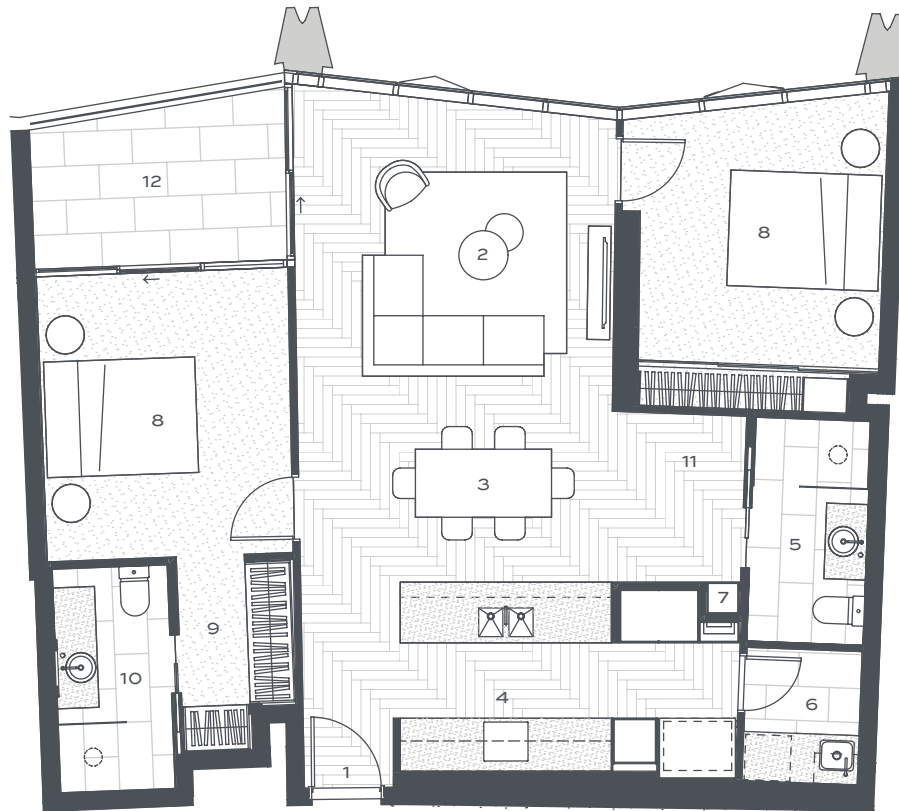
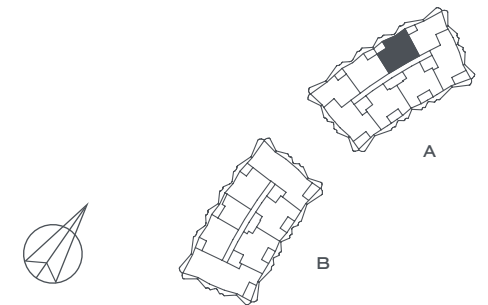

## Sunland Group

Indicative floor plan and artist impression only. Refer to the floor plans contained in the contract of sale for the actual floor plan as variations may apply. All floor areas measured to the centre of external walls and centre line of party walls. All external areas (patio and balconies) are included in the area calculation. External architectural features shown are indicative only. All reasonable care has been taken in the preparation of these floor plans. To the best of our knowledge, no relevant information has been omitted. However Sunland Group Limited and its appointed agents disclaim all liability should any information or matter contained herein differ from the contract of sale or the actual constructed development. Images are illustrative only and all information is correct at the time of printing. © Sunland Group Limited. All rights reserved.

# THE LANES

RESIDENCES

## Type A4

LEVEL 2

UNIT 3204

INTERNAL	95m <sup>2</sup>
EXTERNAL	8m <sup>2</sup>
TOTAL AREA	103m <sup>2</sup>

01 ENTRY 02 LIVING 03 DINING  
 04 KITCHEN 05 BATHROOM 06 LAUNDRY  
 07 LINEN 08 BEDROOM 09 WALK-IN ROBE  
 10 ENSUITE 11 STUDY 12 BALCONY

0m  4m

### WEST VILLAGE KEY PLAN

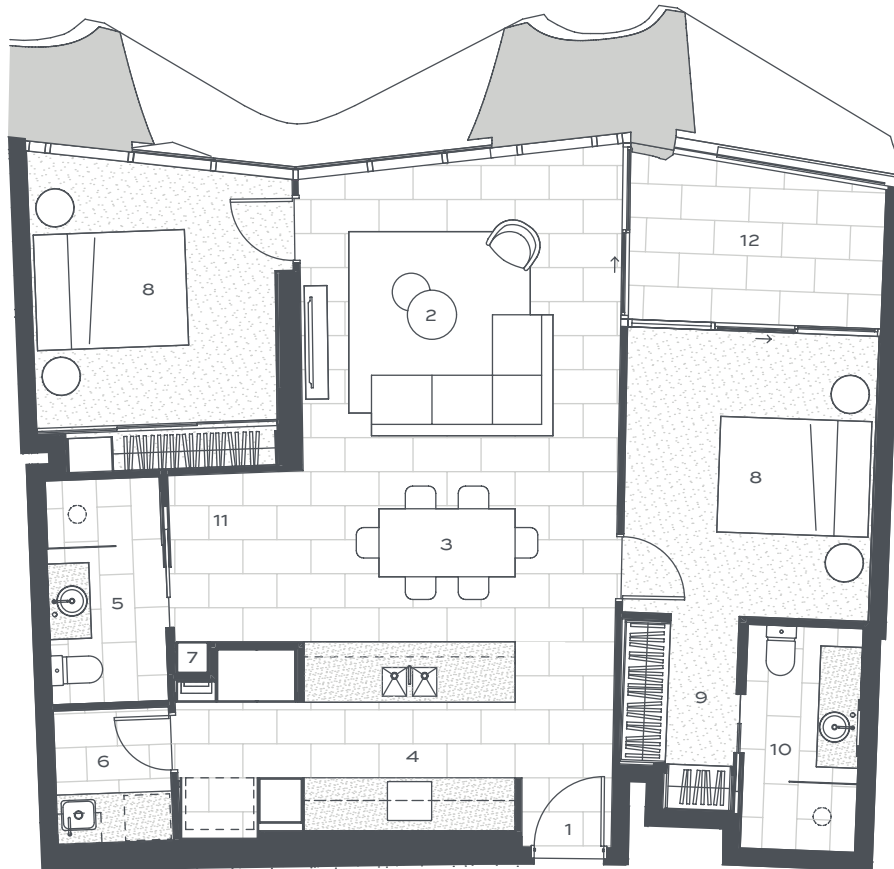
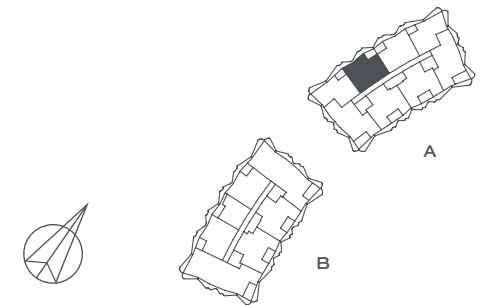

## Sunland Group

Indicative floor plan and artist impression only. Refer to the floor plans contained in the contract of sale for the actual floor plan as variations may apply. All floor areas measured to the centre of external walls and centre line of party walls. All external areas (patio and balconies) are included in the area calculation. External architectural features shown are indicative only. All reasonable care has been taken in the preparation of these floor plans. To the best of our knowledge, no relevant information has been omitted. However Sunland Group Limited and its appointed agents disclaim all liability should any information or matter contained herein differ from the contract of sale or the actual constructed development. Images are illustrative only and all information is correct at the time of printing. © Sunland Group Limited. All rights reserved.

# THE LANES

RESIDENCES

## Type A4

LEVEL 3 - 9  
UNIT 3304, 3404, 3504, 3604, 3704,  
3804, 3904

---

INTERNAL	95m <sup>2</sup>
EXTERNAL	8m <sup>2</sup>
TOTAL AREA	103m <sup>2</sup>

---

01 ENTRY 02 LIVING 03 DINING  
04 KITCHEN 05 BATHROOM 06 LAUNDRY  
07 LINEN 08 BEDROOM 09 WALK-IN ROBE  
10 ENSUITE 11 STUDY 12 BALCONY

---

0m  4m

WEST VILLAGE KEY PLAN

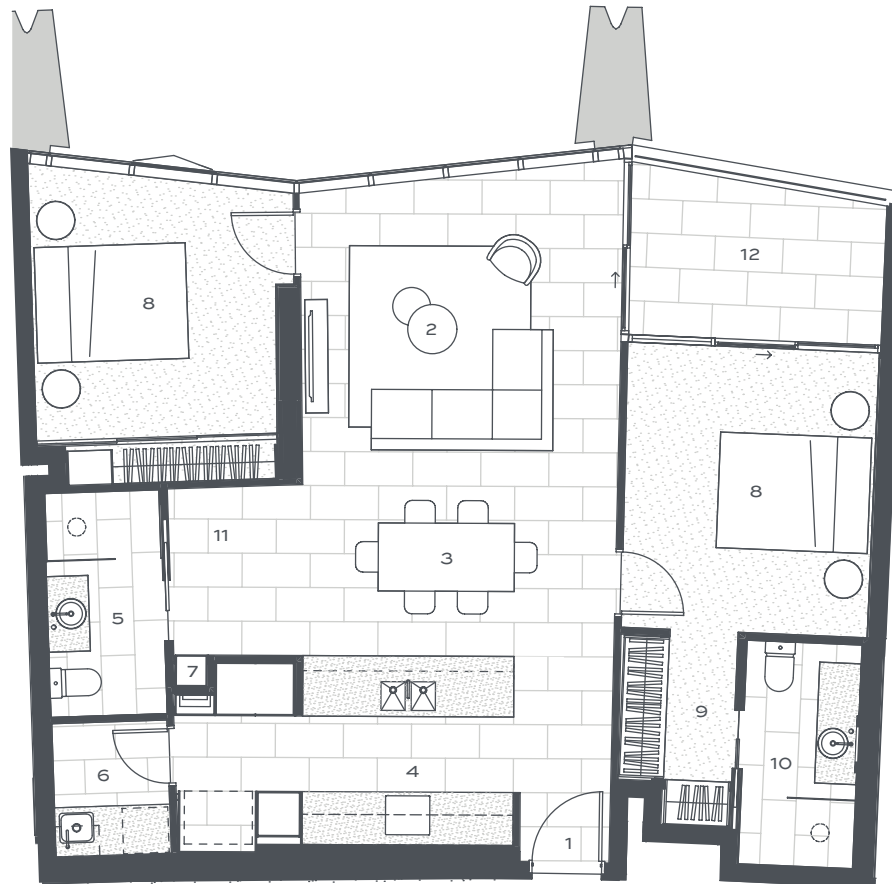
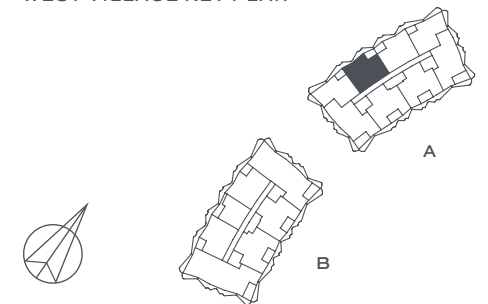

## Sunland Group

Indicative floor plan and artist impression only. Refer to the floor plans contained in the contract of sale for the actual floor plan as variations may apply. All floor areas measured to the centre of external walls and centre line of party walls. All external areas (patio and balconies) are included in the area calculation. External architectural features shown are indicative only. All reasonable care has been taken in the preparation of these floor plans. To the best of our knowledge, no relevant information has been omitted. However Sunland Group Limited and its appointed agents disclaim all liability should any information or matter contained herein differ from the contract of sale or the actual constructed development. Images are illustrative only and all information is correct at the time of printing. © Sunland Group Limited. All rights reserved.

# THE LANES

RESIDENCES

## Type A4

LEVEL 10

UNIT 31004

---

INTERNAL	95m <sup>2</sup>
EXTERNAL	8m <sup>2</sup>
TOTAL AREA	103m <sup>2</sup>

---

01 ENTRY 02 LIVING 03 DINING  
04 KITCHEN 05 BATHROOM 06 LAUNDRY  
07 LINEN 08 BEDROOM 09 WALK-IN ROBE  
10 ENSUITE 11 STUDY 12 BALCONY

---

0m  4m

### WEST VILLAGE KEY PLAN

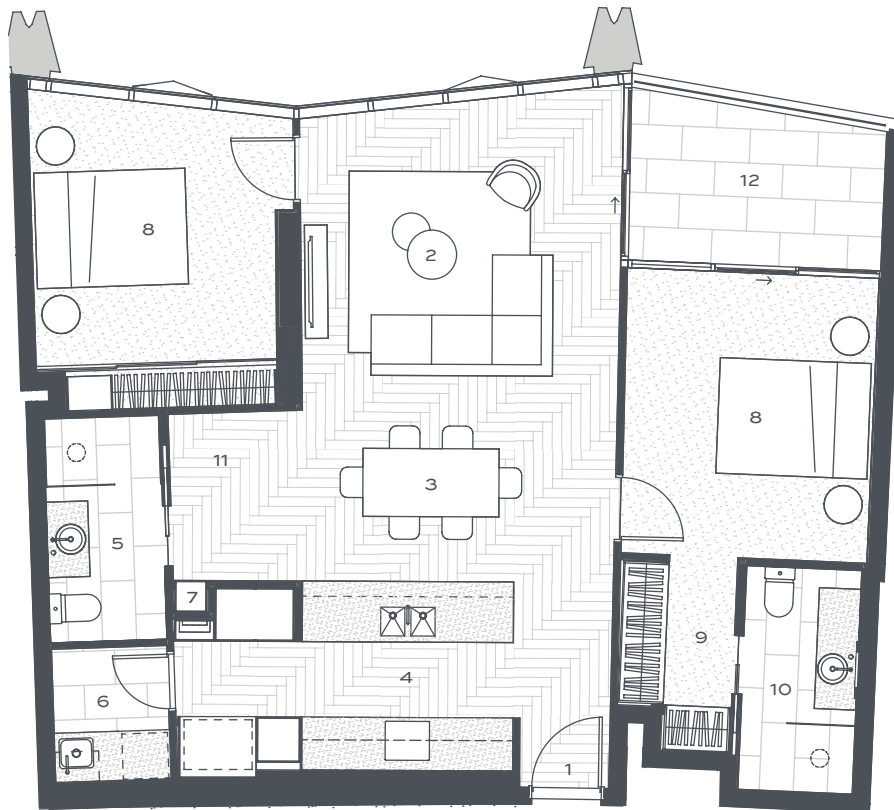
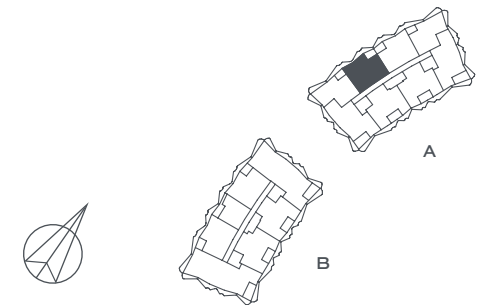

## Sunland Group

Indicative floor plan and artist impression only. Refer to the floor plans contained in the contract of sale for the actual floor plan as variations may apply. All floor areas measured to the centre of external walls and centre line of party walls. All external areas (patio and balconies) are included in the area calculation. External architectural features shown are indicative only. All reasonable care has been taken in the preparation of these floor plans. To the best of our knowledge, no relevant information has been omitted. However Sunland Group Limited and its appointed agents disclaim all liability should any information or matter contained herein differ from the contract of sale or the actual constructed development. Images are illustrative only and all information is correct at the time of printing. © Sunland Group Limited. All rights reserved.

# THE LANES

RESIDENCES

## Type A5.m

LEVEL 2

UNIT 3206

---

INTERNAL	89m <sup>2</sup>
EXTERNAL	7m <sup>2</sup>
TOTAL AREA	96m <sup>2</sup>

---

01 ENTRY 02 LIVING 03 DINING  
04 KITCHEN 05 BATHROOM 06 LAUNDRY  
07 LINEN 08 BEDROOM 09 ENSUITE  
10 BALCONY

---

0m  4m

WEST VILLAGE KEY PLAN

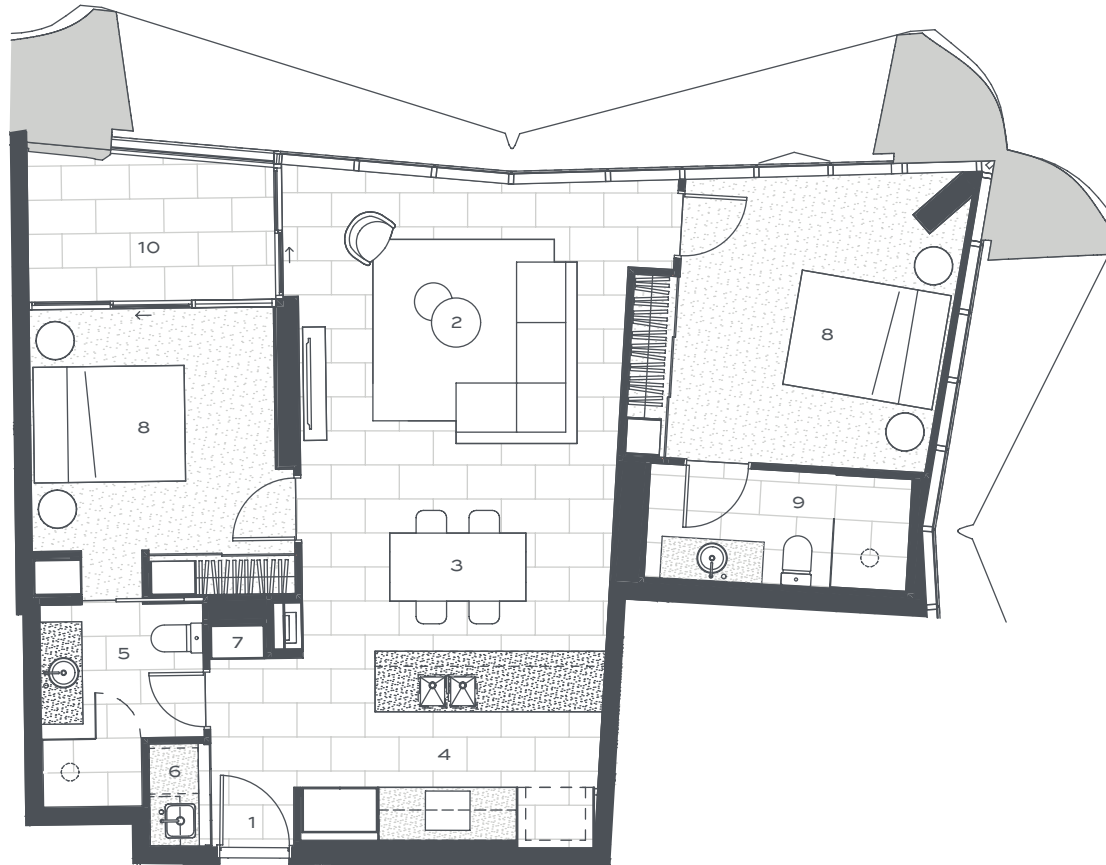
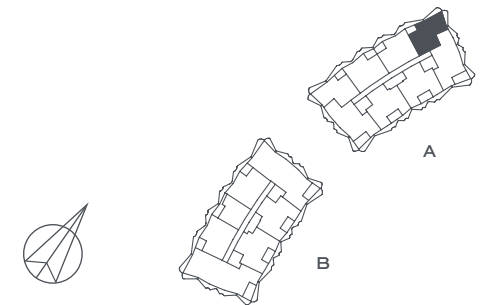

## Sunland Group

Indicative floor plan and artist impression only. Refer to the floor plans contained in the contract of sale for the actual floor plan as variations may apply. All floor areas measured to the centre of external walls and centre line of party walls. All external areas (patio and balconies) are included in the area calculation. External architectural features shown are indicative only. All reasonable care has been taken in the preparation of these floor plans. To the best of our knowledge, no relevant information has been omitted. However Sunland Group Limited and its appointed agents disclaim all liability should any information or matter contained herein differ from the contract of sale or the actual constructed development. Images are illustrative only and all information is correct at the time of printing. © Sunland Group Limited. All rights reserved.

# THE LANES

RESIDENCES

## Type A5.m

LEVEL 3 - 6

UNIT 3306, 3406, 3506, 3606

---

INTERNAL	89m <sup>2</sup>
EXTERNAL	7m <sup>2</sup>
TOTAL AREA	96m <sup>2</sup>

---

01 ENTRY 02 LIVING 03 DINING  
04 KITCHEN 05 BATHROOM 06 LAUNDRY  
07 LINEN 08 BEDROOM 09 ENSUITE  
10 BALCONY

---

0m  4m

WEST VILLAGE KEY PLAN

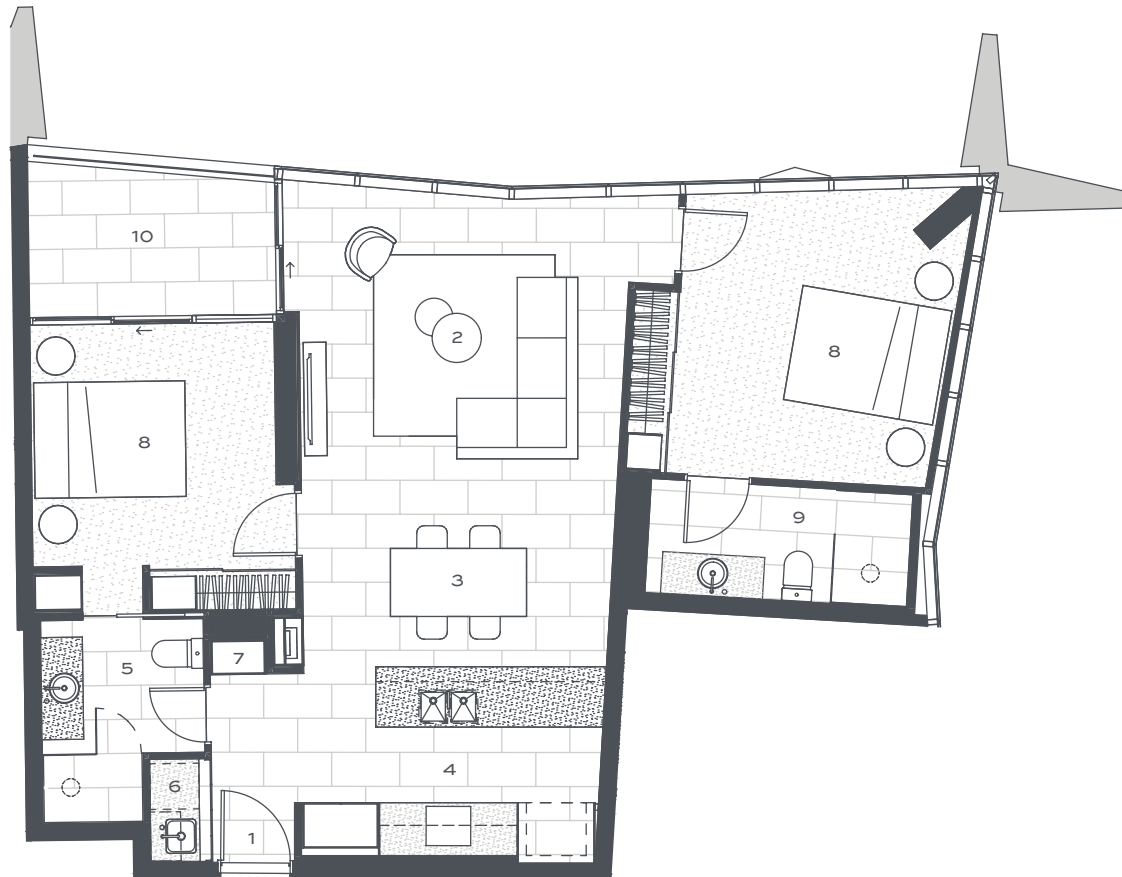
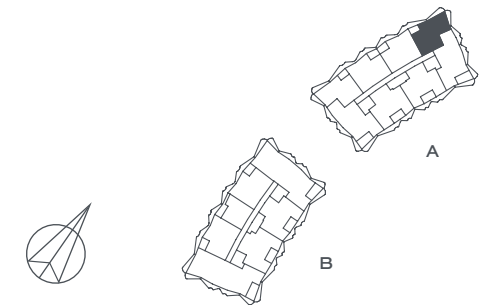

## Sunland Group

Indicative floor plan and artist impression only. Refer to the floor plans contained in the contract of sale for the actual floor plan as variations may apply. All floor areas measured to the centre of external walls and centre line of party walls. All external areas (patio and balconies) are included in the area calculation. External architectural features shown are indicative only. All reasonable care has been taken in the preparation of these floor plans. To the best of our knowledge, no relevant information has been omitted. However Sunland Group Limited and its appointed agents disclaim all liability should any information or matter contained herein differ from the contract of sale or the actual constructed development. Images are illustrative only and all information is correct at the time of printing. © Sunland Group Limited. All rights reserved.



# THE LANES

RESIDENCES

## Type A5

LEVEL 2

UNIT 3203

---

INTERNAL	89m <sup>2</sup>
EXTERNAL	7m <sup>2</sup>
TOTAL AREA	96m <sup>2</sup>

---

01 ENTRY 02 LIVING 03 DINING  
04 KITCHEN 05 BATHROOM 06 LAUNDRY  
07 LINEN 08 BEDROOM 09 ENSUITE  
10 BALCONY

---

0m  4m

WEST VILLAGE KEY PLAN

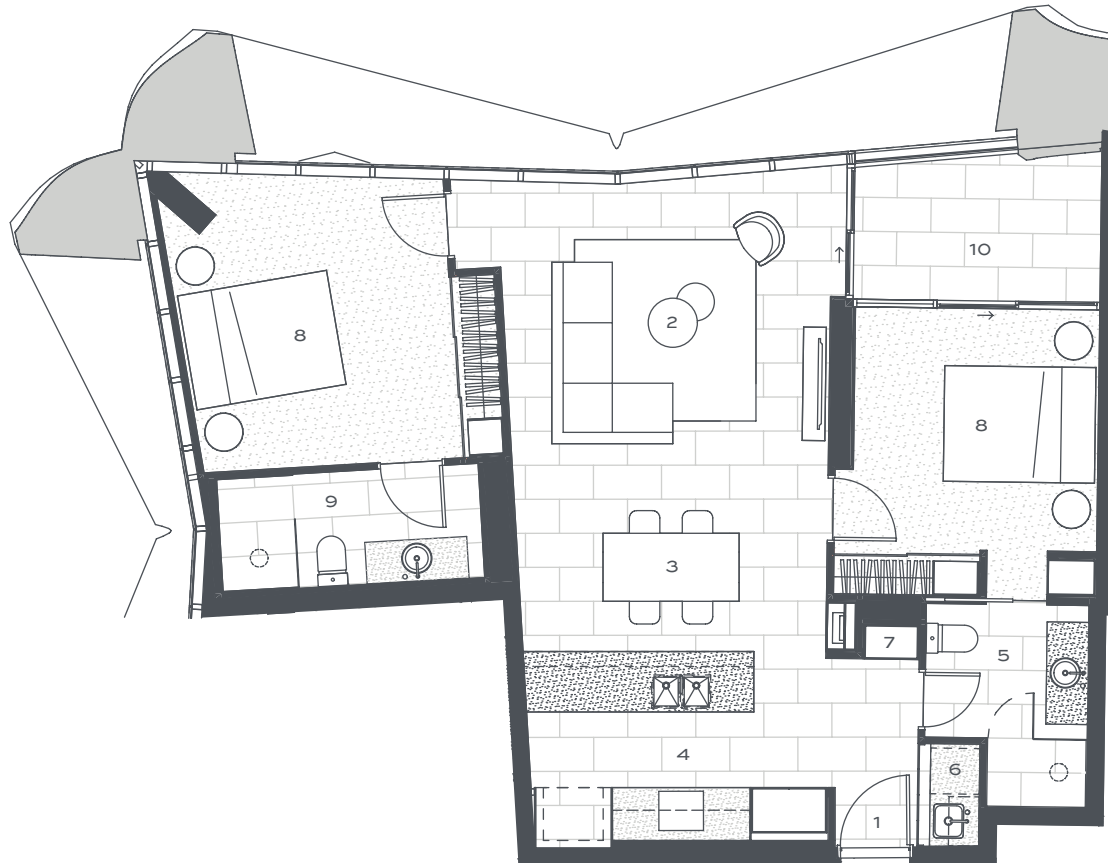
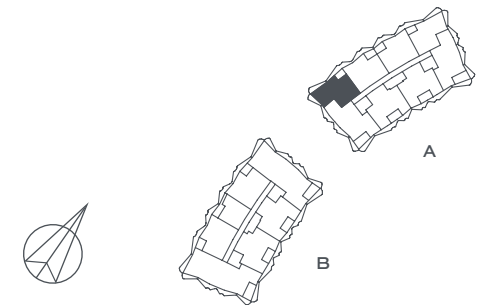

## Sunland Group

Indicative floor plan and artist impression only. Refer to the floor plans contained in the contract of sale for the actual floor plan as variations may apply. All floor areas measured to the centre of external walls and centre line of party walls. All external areas (patio and balconies) are included in the area calculation. External architectural features shown are indicative only. All reasonable care has been taken in the preparation of these floor plans. To the best of our knowledge, no relevant information has been omitted. However Sunland Group Limited and its appointed agents disclaim all liability should any information or matter contained herein differ from the contract of sale or the actual constructed development. Images are illustrative only and all information is correct at the time of printing. © Sunland Group Limited. All rights reserved.

# THE LANES

RESIDENCES

## Type A5

LEVEL 3 - 6

UNIT 3303, 3403, 3503, 3603

---

INTERNAL	89m <sup>2</sup>
EXTERNAL	7m <sup>2</sup>
TOTAL AREA	96m <sup>2</sup>

---

01 ENTRY 02 LIVING 03 DINING  
04 KITCHEN 05 BATHROOM 06 LAUNDRY  
07 LINEN 08 BEDROOM 09 ENSUITE  
10 BALCONY

---

0m  4m

WEST VILLAGE KEY PLAN

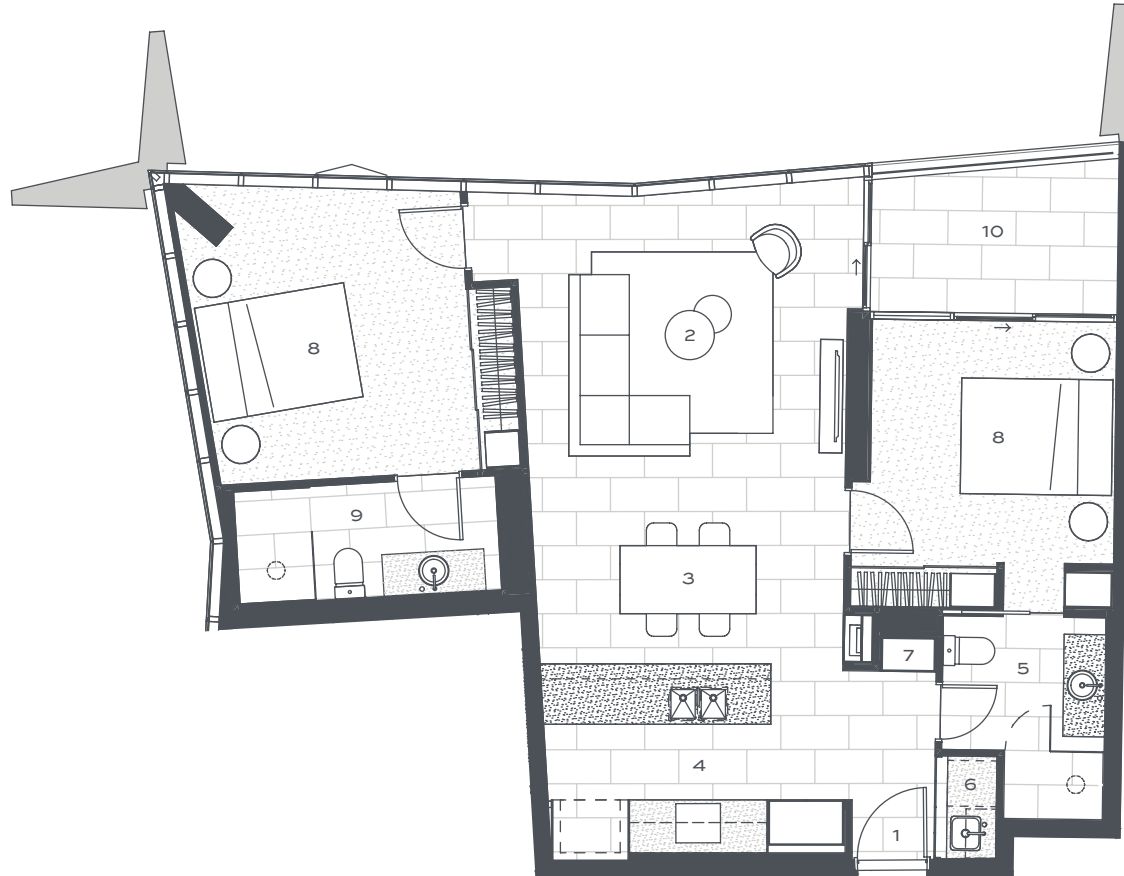
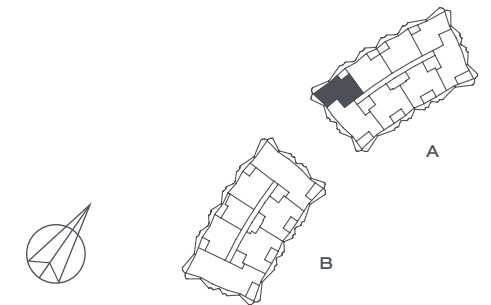

## Sunland Group

Indicative floor plan and artist impression only. Refer to the floor plans contained in the contract of sale for the actual floor plan as variations may apply. All floor areas measured to the centre of external walls and centre line of party walls. All external areas (patio and balconies) are included in the area calculation. External architectural features shown are indicative only. All reasonable care has been taken in the preparation of these floor plans. To the best of our knowledge, no relevant information has been omitted. However Sunland Group Limited and its appointed agents disclaim all liability should any information or matter contained herein differ from the contract of sale or the actual constructed development. Images are illustrative only and all information is correct at the time of printing. © Sunland Group Limited. All rights reserved.

# THE LANES

RESIDENCES

## Type A6.m

LEVEL 7 - 9

UNIT 3706, 3806, 3906

---

INTERNAL	62m <sup>2</sup>
EXTERNAL	7m <sup>2</sup>
TOTAL AREA	69m <sup>2</sup>

---

01 ENTRY 02 LIVING 03 DINING  
04 KITCHEN 05 BATHROOM 06 LAUNDRY  
07 LINEN 08 BEDROOM 09 BALCONY

---

0m  4m

WEST VILLAGE KEY PLAN

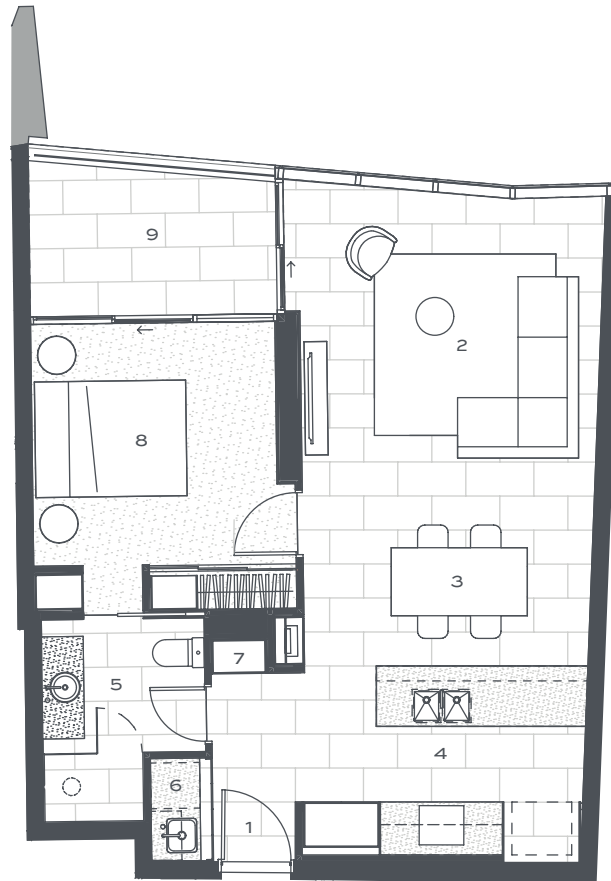
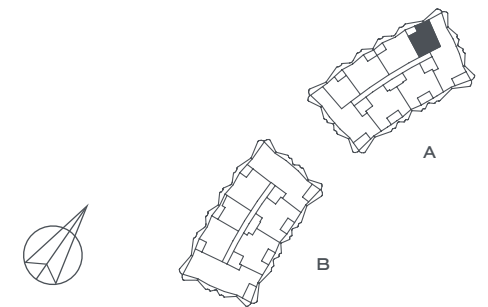

## Sunland Group

Indicative floor plan and artist impression only. Refer to the floor plans contained in the contract of sale for the actual floor plan as variations may apply. All floor areas measured to the centre of external walls and centre line of party walls. All external areas (patio and balconies) are included in the area calculation. External architectural features shown are indicative only. All reasonable care has been taken in the preparation of these floor plans. To the best of our knowledge, no relevant information has been omitted. However Sunland Group Limited and its appointed agents disclaim all liability should any information or matter contained herein differ from the contract of sale or the actual constructed development. Images are illustrative only and all information is correct at the time of printing. © Sunland Group Limited. All rights reserved.

# THE LANES

RESIDENCES

## Type A6.m

LEVEL 10

UNIT 31006

---

INTERNAL	62m <sup>2</sup>
EXTERNAL	7m <sup>2</sup>
TOTAL AREA	69m <sup>2</sup>

---

01 ENTRY 02 LIVING 03 DINING  
04 KITCHEN 05 BATHROOM 06 LAUNDRY  
07 LINEN 08 BEDROOM 09 BALCONY

---

0m  4m

WEST VILLAGE KEY PLAN

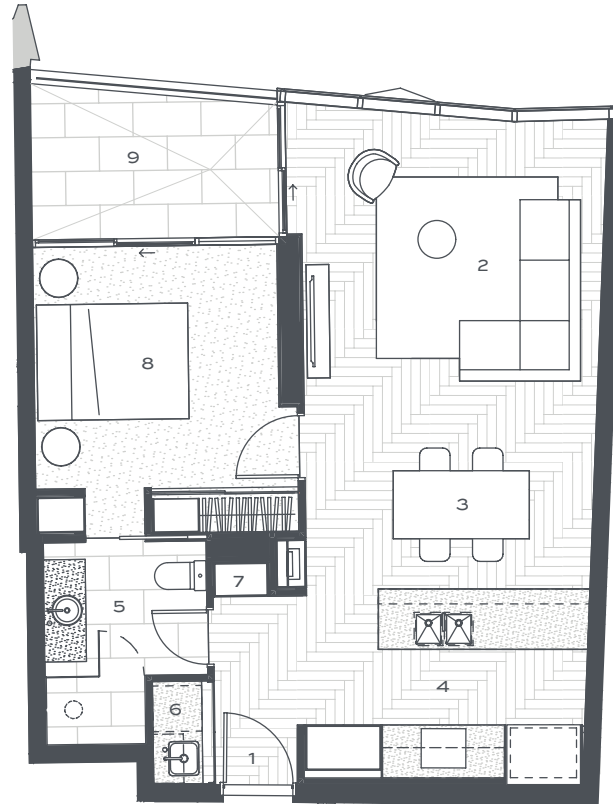
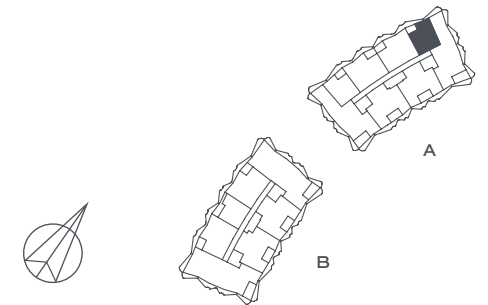

## Sunland Group

Indicative floor plan and artist impression only. Refer to the floor plans contained in the contract of sale for the actual floor plan as variations may apply. All floor areas measured to the centre of external walls and centre line of party walls. All external areas (patio and balconies) are included in the area calculation. External architectural features shown are indicative only. All reasonable care has been taken in the preparation of these floor plans. To the best of our knowledge, no relevant information has been omitted. However Sunland Group Limited and its appointed agents disclaim all liability should any information or matter contained herein differ from the contract of sale or the actual constructed development. Images are illustrative only and all information is correct at the time of printing. © Sunland Group Limited. All rights reserved.

# THE LANES

RESIDENCES

## Type A6

LEVEL 7 - 9

UNIT 3703, 3803, 3903

---

INTERNAL	62m <sup>2</sup>
EXTERNAL	7m <sup>2</sup>
TOTAL AREA	69m <sup>2</sup>

---

01 ENTRY 02 LIVING 03 DINING  
04 KITCHEN 05 BATHROOM 06 LAUNDRY  
07 LINEN 08 BEDROOM 09 BALCONY

---

0m  4m

### WEST VILLAGE KEY PLAN

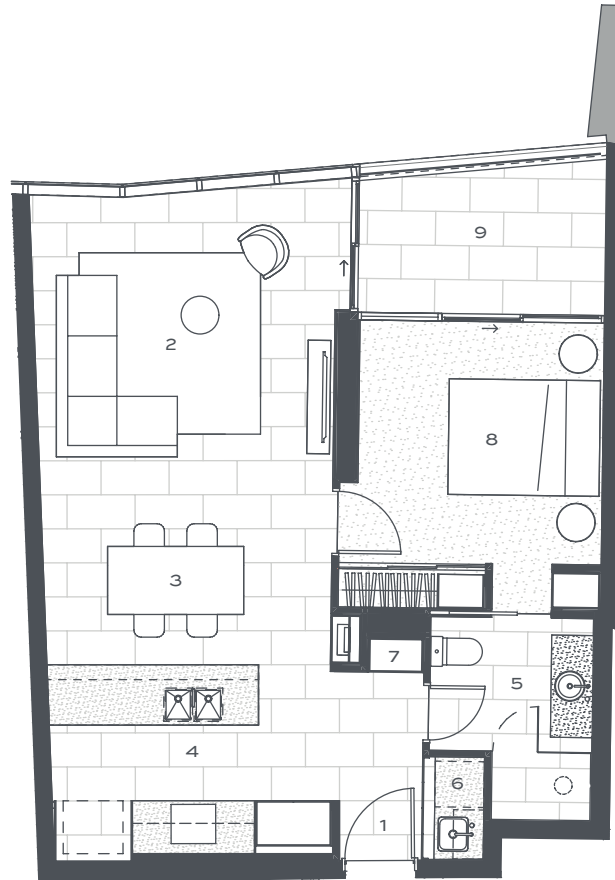
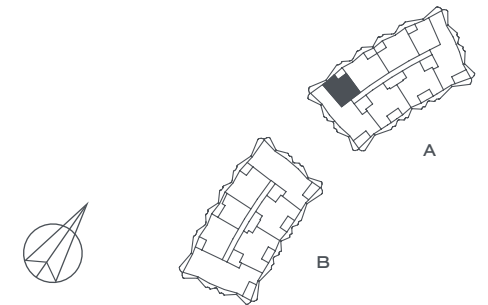

## Sunland Group

Indicative floor plan and artist impression only. Refer to the floor plans contained in the contract of sale for the actual floor plan as variations may apply. All floor areas measured to the centre of external walls and centre line of party walls. All external areas (patio and balconies) are included in the area calculation. External architectural features shown are indicative only. All reasonable care has been taken in the preparation of these floor plans. To the best of our knowledge, no relevant information has been omitted. However Sunland Group Limited and its appointed agents disclaim all liability should any information or matter contained herein differ from the contract of sale or the actual constructed development. Images are illustrative only and all information is correct at the time of printing. © Sunland Group Limited. All rights reserved.

# THE LANES

RESIDENCES

## Type A6

LEVEL 10

UNIT 31003

---

INTERNAL	62m <sup>2</sup>
EXTERNAL	7m <sup>2</sup>
TOTAL AREA	69m <sup>2</sup>

---

01 ENTRY 02 LIVING 03 DINING  
04 KITCHEN 05 BATHROOM 06 LAUNDRY  
07 LINEN 08 BEDROOM 09 BALCONY

---

0m  4m

### WEST VILLAGE KEY PLAN

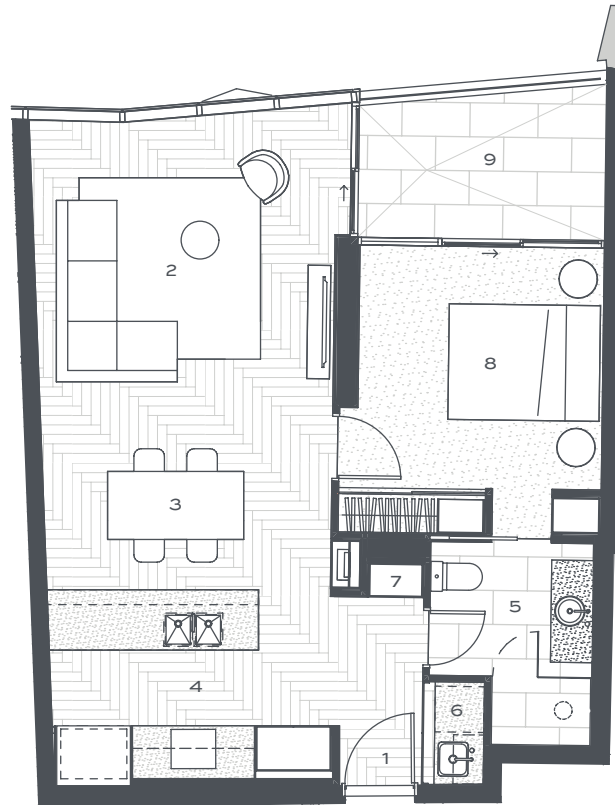
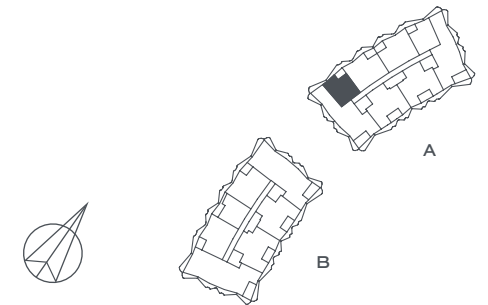

## Sunland Group

Indicative floor plan and artist impression only. Refer to the floor plans contained in the contract of sale for the actual floor plan as variations may apply. All floor areas measured to the centre of external walls and centre line of party walls. All external areas (patio and balconies) are included in the area calculation. External architectural features shown are indicative only. All reasonable care has been taken in the preparation of these floor plans. To the best of our knowledge, no relevant information has been omitted. However Sunland Group Limited and its appointed agents disclaim all liability should any information or matter contained herein differ from the contract of sale or the actual constructed development. Images are illustrative only and all information is correct at the time of printing. © Sunland Group Limited. All rights reserved.

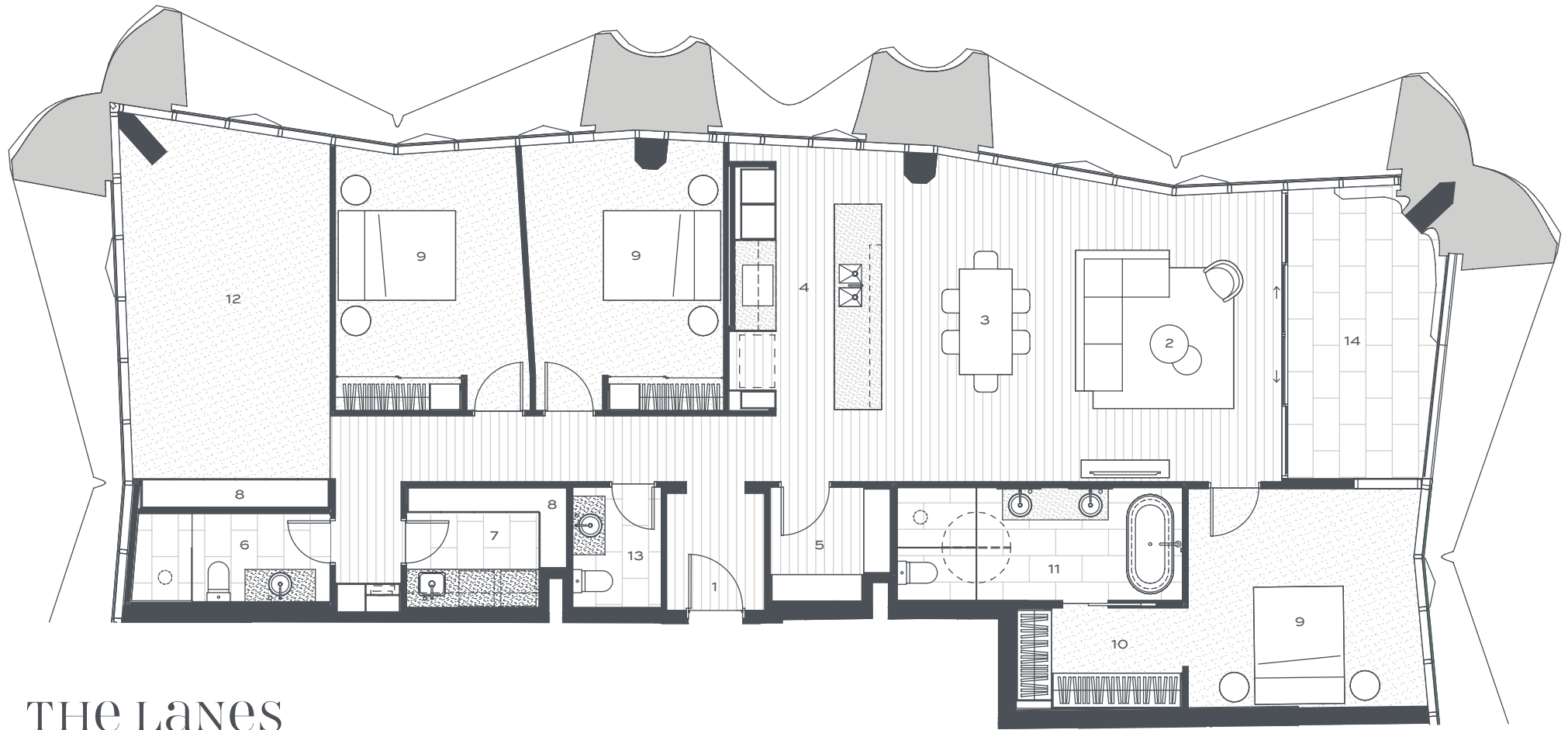

# THE LANES

RESIDENCES

## Type B1.m

LEVEL 2  
UNIT 4206

INTERNAL	176m <sup>2</sup>
EXTERNAL	14m <sup>2</sup>
TOTAL AREA	190m <sup>2</sup>

0m 4m



WEST VILLAGE KEY PLAN

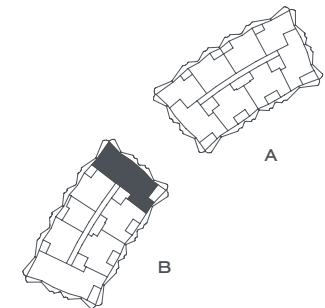

01 ENTRY 02 LIVING 03 DINING 04 KITCHEN 05 PANTRY 06 BATHROOM 07 LAUNDRY 08 LINEN 09 BEDROOM 10 WALK-IN ROBE  
11 ENSUITE 12 MULTI PURPOSE 13 POWDER ROOM 14 BALCONY

Indicative floor plan and artist impression only. Refer to the floor plans contained in the contract of sale for the actual floor plan as variations may apply. All floor areas measured to the centre of external walls and centre line of party walls. All external areas (patio and balconies) are included in the area calculation. External architectural features shown are indicative only. All reasonable care has been taken in the preparation of these floor plans. To the best of our knowledge, no relevant information has been omitted. However Sunland Group Limited and its appointed agents disclaim all liability should any information or matter contained herein differ from the contract of sale or the actual constructed development. Images are illustrative only and all information is correct at the time of printing. © Sunland Group Limited. All rights reserved.

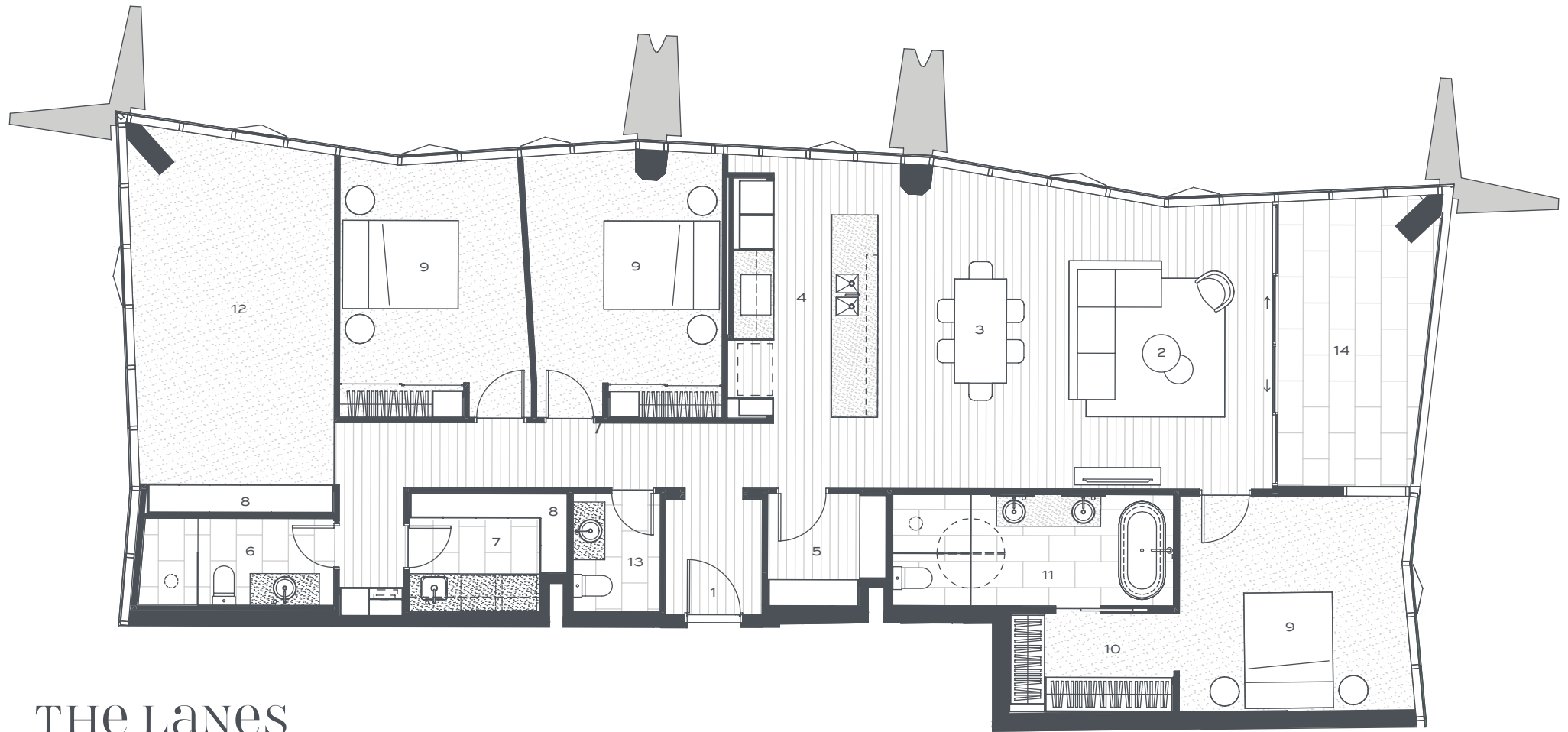

# THE LANES

RESIDENCES

## Type B1.m

LEVEL 3 - 11

UNIT 4306, 4406, 4506, 4606, 4706,  
4806, 4906, 41006, 41106

INTERNAL	176m <sup>2</sup>
EXTERNAL	14m <sup>2</sup>
TOTAL AREA	190m <sup>2</sup>

0m 4m



WEST VILLAGE KEY PLAN

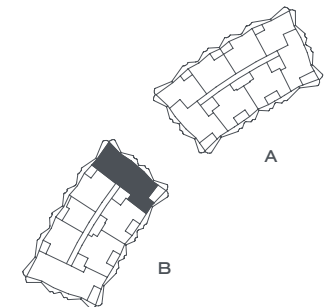

01 ENTRY 02 LIVING 03 DINING 04 KITCHEN 05 PANTRY 06 BATHROOM 07 LAUNDRY 08 LINEN 09 BEDROOM 10 WALK-IN ROBE  
11 ENSUITE 12 MULTI PURPOSE 13 POWDER ROOM 14 BALCONY

Indicative floor plan and artist impression only. Refer to the floor plans contained in the contract of sale for the actual floor plan as variations may apply. All floor areas measured to the centre of external walls and centre line of party walls. All external areas (patio and balconies) are included in the area calculation. External architectural features shown are indicative only. All reasonable care has been taken in the preparation of these floor plans. To the best of our knowledge, no relevant information has been omitted. However Sunland Group Limited and its appointed agents disclaim all liability should any information or matter contained herein differ from the contract of sale or the actual constructed development. Images are illustrative only and all information is correct at the time of printing. © Sunland Group Limited. All rights reserved.



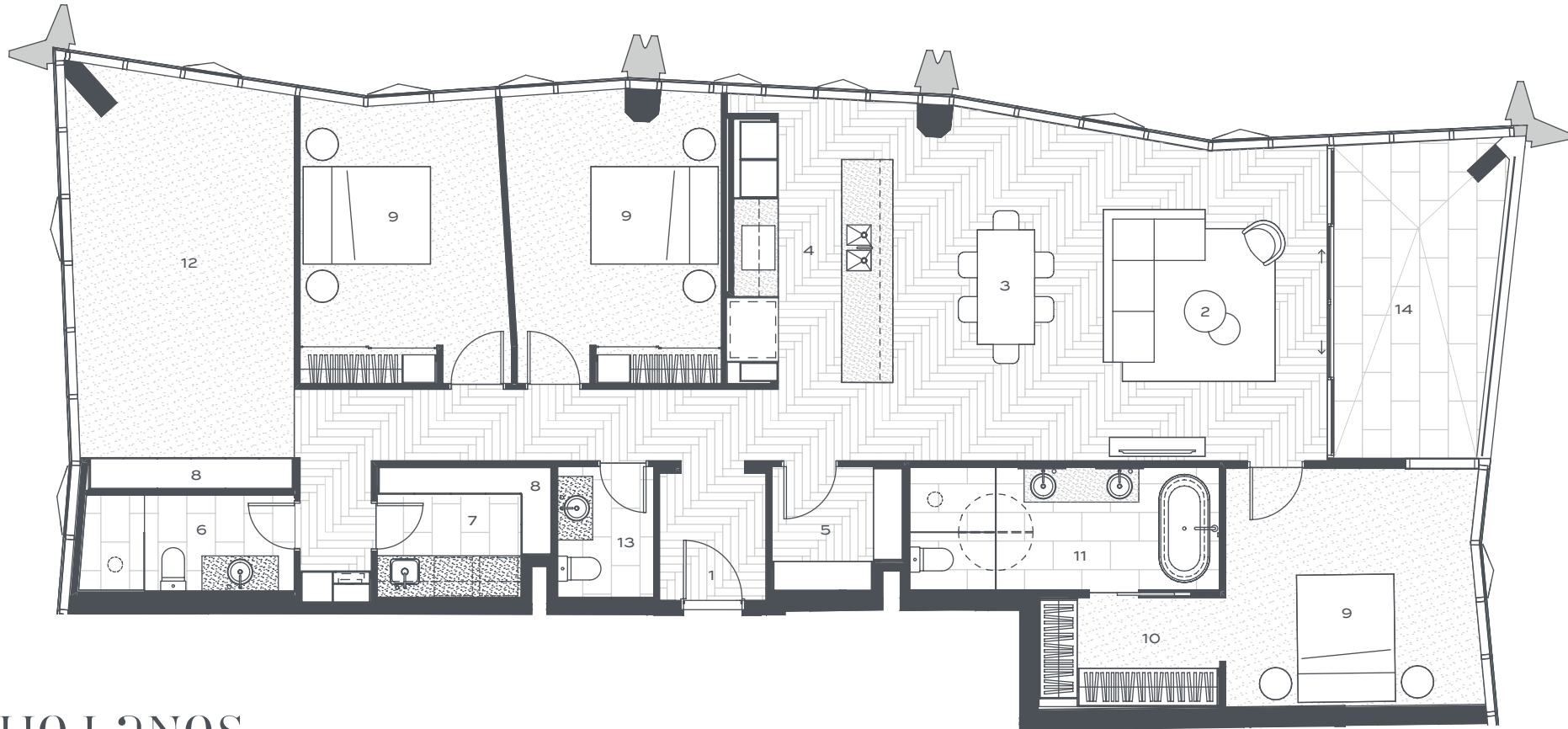

# THE LANES

RESIDENCES

## Type B1.m

LEVEL 12  
UNIT 41206

INTERNAL 176m<sup>2</sup>  
EXTERNAL 14m<sup>2</sup>  
TOTAL AREA 190m<sup>2</sup>

0m 4m



WEST VILLAGE KEY PLAN

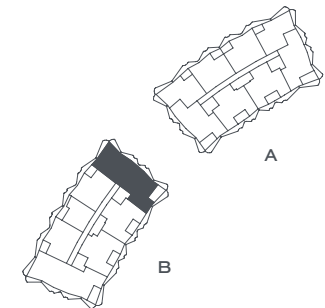

01 ENTRY 02 LIVING 03 DINING 04 KITCHEN 05 PANTRY 06 BATHROOM 07 LAUNDRY 08 LINEN 09 BEDROOM 10 WALK-IN ROBE  
11 ENSUITE 12 MULTI PURPOSE 13 POWDER ROOM 14 BALCONY

Indicative floor plan and artist impression only. Refer to the floor plans contained in the contract of sale for the actual floor plan as variations may apply. All floor areas measured to the centre of external walls and centre line of party walls. All external areas (patio and balconies) are included in the area calculation. External architectural features shown are indicative only. All reasonable care has been taken in the preparation of these floor plans. To the best of our knowledge, no relevant information has been omitted. However Sunland Group Limited and its appointed agents disclaim all liability should any information or matter contained herein differ from the contract of sale or the actual constructed development. Images are illustrative only and all information is correct at the time of printing. © Sunland Group Limited. All rights reserved.

# THE LANES

RESIDENCES

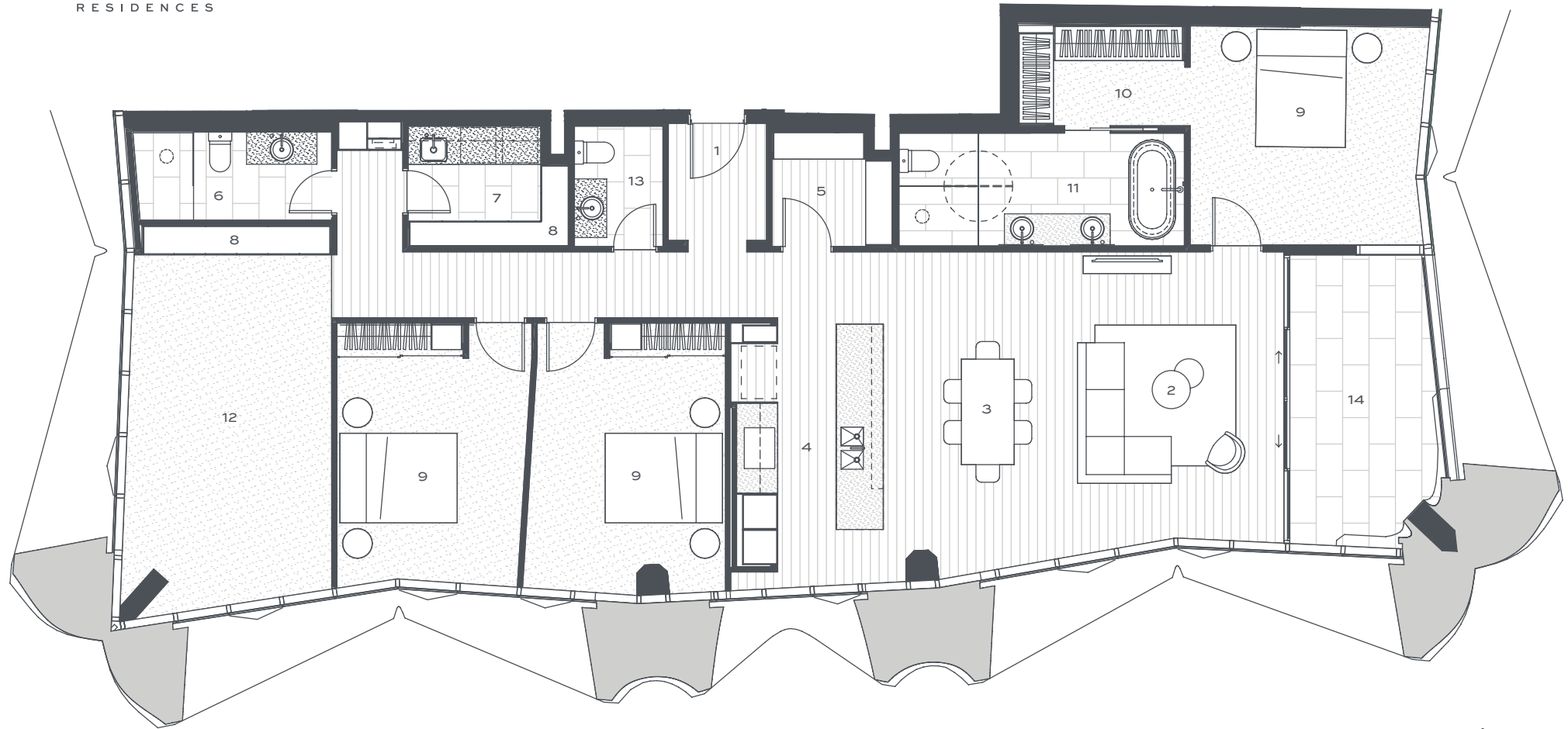

## Type B1

LEVEL 2  
UNIT 4202

INTERNAL	176m <sup>2</sup>
EXTERNAL	14m <sup>2</sup>
TOTAL AREA	190m <sup>2</sup>

0m 4m



WEST VILLAGE KEY PLAN

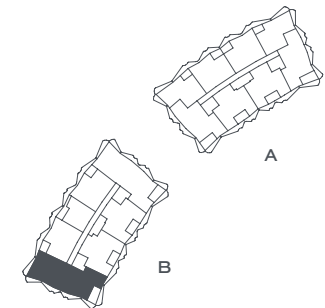

01 ENTRY 02 LIVING 03 DINING 04 KITCHEN 05 PANTRY 06 BATHROOM 07 LAUNDRY 08 LINEN 09 BEDROOM 10 WALK-IN ROBE  
11 ENSUITE 12 MULTI PURPOSE 13 POWDER ROOM 14 BALCONY

Indicative floor plan and artist impression only. Refer to the floor plans contained in the contract of sale for the actual floor plan as variations may apply. All floor areas measured to the centre of external walls and centre line of party walls. All external areas (patio and balconies) are included in the area calculation. External architectural features shown are indicative only. All reasonable care has been taken in the preparation of these floor plans. To the best of our knowledge, no relevant information has been omitted. However Sunland Group Limited and its appointed agents disclaim all liability should any information or matter contained herein differ from the contract of sale or the actual constructed development. Images are illustrative only and all information is correct at the time of printing. © Sunland Group Limited. All rights reserved.

# THE LANES

RESIDENCES

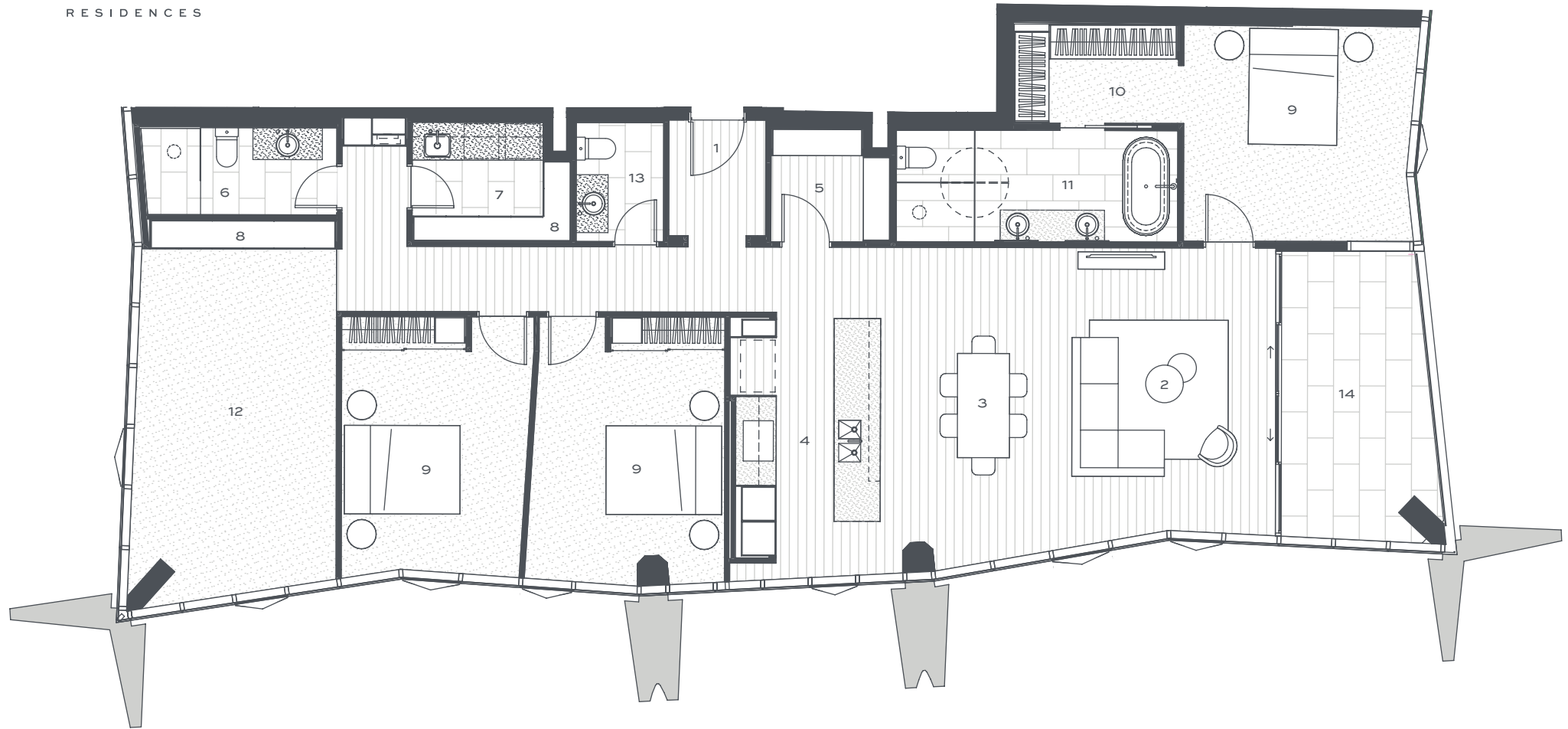

## Type B1

**LEVEL** 3 - 11  
**UNIT** 4302, 4402, 4502, 4602, 4702,  
 4802, 4902, 41002, 41102

**INTERNAL** 176m<sup>2</sup>  
**EXTERNAL** 14m<sup>2</sup>  
**TOTAL AREA** 190m<sup>2</sup>

0m 4m



WEST VILLAGE KEY PLAN

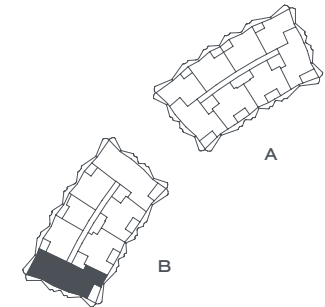

**01** ENTRY **02** LIVING **03** DINING **04** KITCHEN **05** PANTRY **06** BATHROOM **07** LAUNDRY **08** LINEN **09** BEDROOM **10** WALK-IN ROBE  
**11** ENSUITE **12** MULTI PURPOSE **13** POWDER ROOM **14** BALCONY

Indicative floor plan and artist impression only. Refer to the floor plans contained in the contract of sale for the actual floor plan as variations may apply. All floor areas measured to the centre of external walls and centre line of party walls. All external areas (patio and balconies) are included in the area calculation. External architectural features shown are indicative only. All reasonable care has been taken in the preparation of these floor plans. To the best of our knowledge, no relevant information has been omitted. However Sunland Group Limited and its appointed agents disclaim all liability should any information or matter contained herein differ from the contract of sale or the actual constructed development. Images are illustrative only and all information is correct at the time of printing. © Sunland Group Limited. All rights reserved.

# THE LANES

RESIDENCES

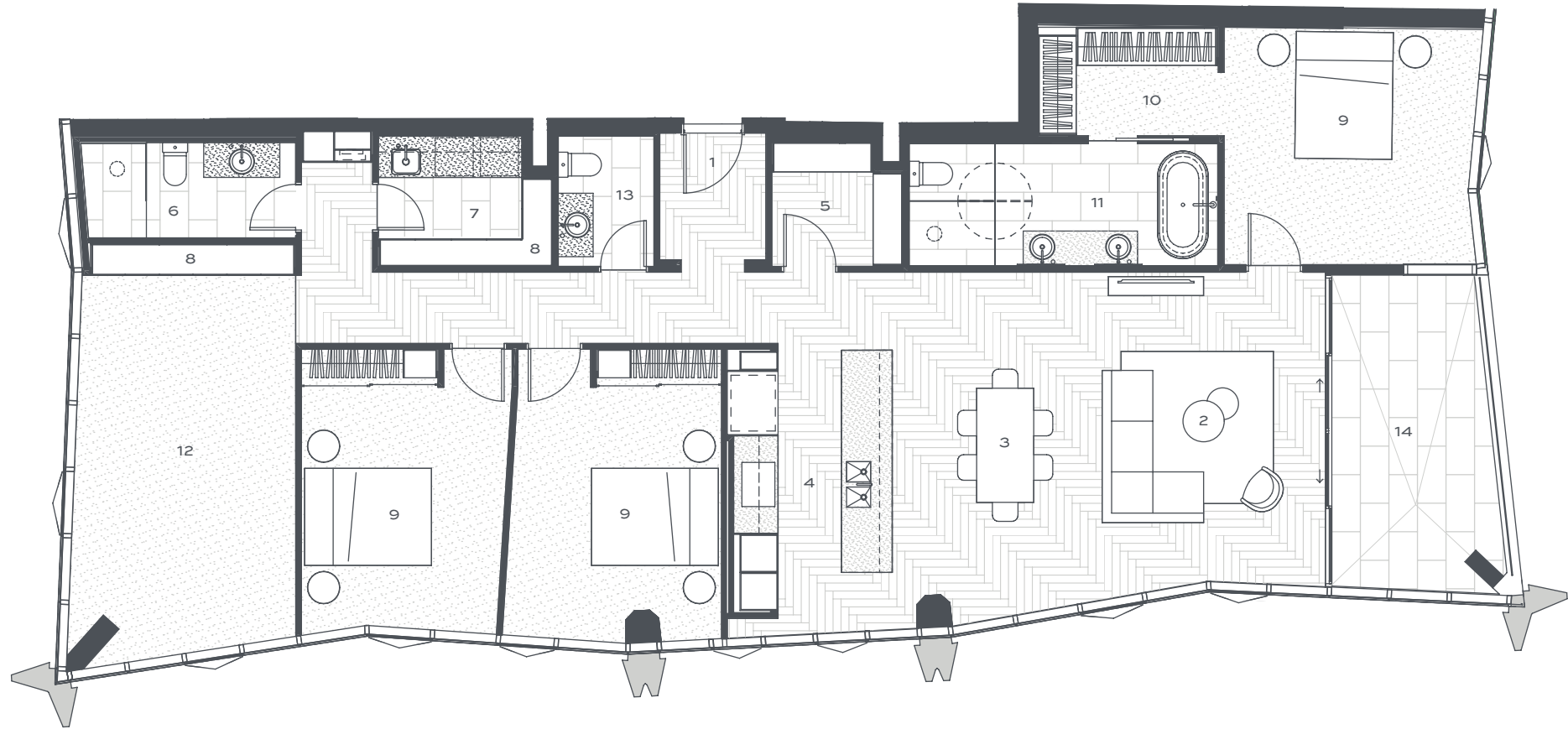

## Type B1

LEVEL 12  
UNIT 41202

INTERNAL	176m <sup>2</sup>
EXTERNAL	14m <sup>2</sup>
TOTAL AREA	190m <sup>2</sup>

0m 4m



WEST VILLAGE KEY PLAN

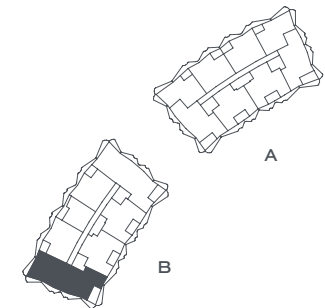

01 ENTRY 02 LIVING 03 DINING 04 KITCHEN 05 PANTRY 06 BATHROOM 07 LAUNDRY 08 LINEN 09 BEDROOM 10 WALK-IN ROBE  
11 ENSUITE 12 MULTI PURPOSE 13 POWDER ROOM 14 BALCONY

Indicative floor plan and artist impression only. Refer to the floor plans contained in the contract of sale for the actual floor plan as variations may apply. All floor areas measured to the centre of external walls and centre line of party walls. All external areas (patio and balconies) are included in the area calculation. External architectural features shown are indicative only. All reasonable care has been taken in the preparation of these floor plans. To the best of our knowledge, no relevant information has been omitted. However Sunland Group Limited and its appointed agents disclaim all liability should any information or matter contained herein differ from the contract of sale or the actual constructed development. Images are illustrative only and all information is correct at the time of printing. © Sunland Group Limited. All rights reserved.

# THE LANES

RESIDENCES

## Type B2.1

LEVEL 2  
UNIT 4207

INTERNAL	109m <sup>2</sup>
EXTERNAL	12m <sup>2</sup>
TOTAL AREA	121m <sup>2</sup>

01 ENTRY 02 LIVING 03 DINING  
04 KITCHEN 05 PANTRY 06 BATHROOM  
07 LAUNDRY 08 LINEN 09 BEDROOM  
10 WALK-IN ROBE 11 ENSUITE 12 STUDY  
13 BALCONY

0m  4m

WEST VILLAGE KEY PLAN

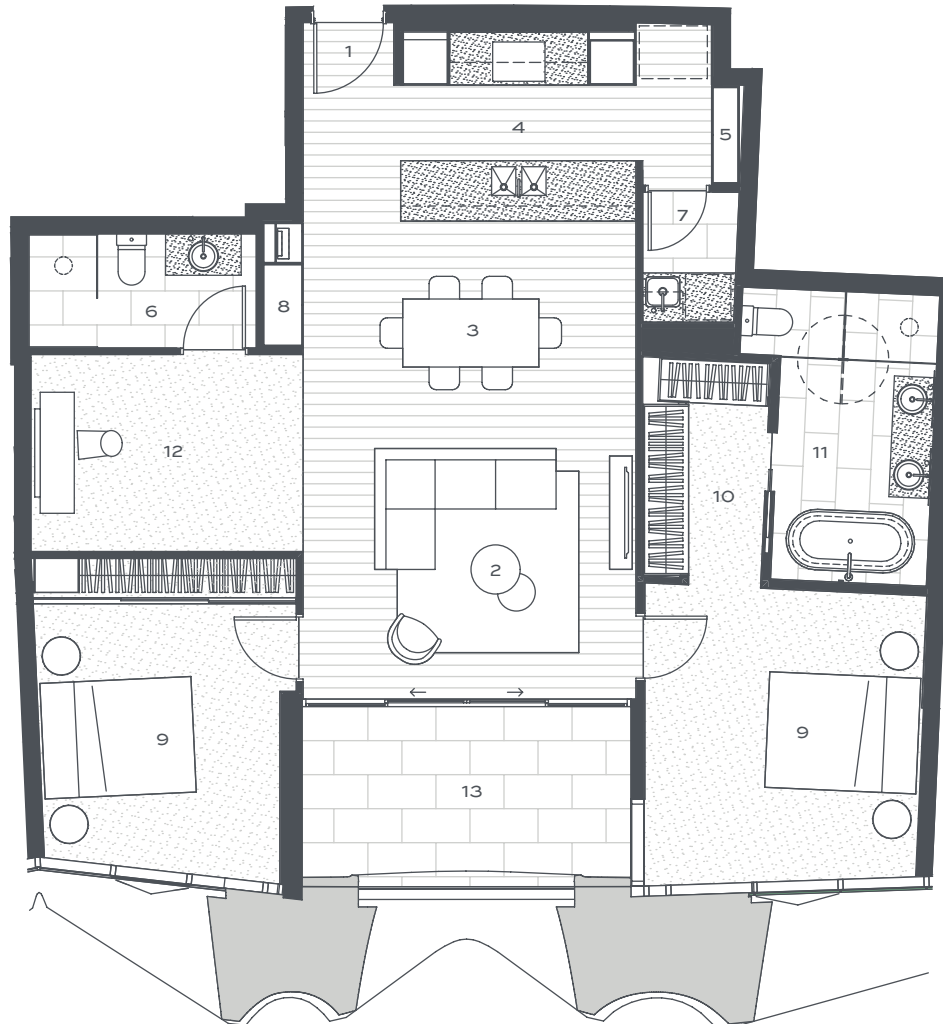
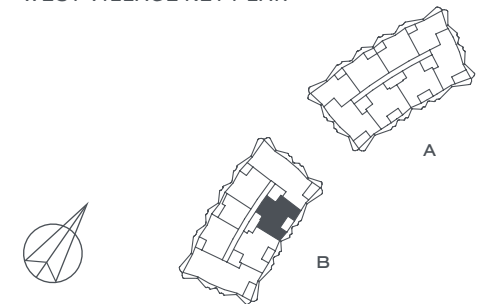

## Sunland Group

Indicative floor plan and artist impression only. Refer to the floor plans contained in the contract of sale for the actual floor plan as variations may apply. All floor areas measured to the centre of external walls and centre line of party walls. All external areas (patio and balconies) are included in the area calculation. External architectural features shown are indicative only. All reasonable care has been taken in the preparation of these floor plans. To the best of our knowledge, no relevant information has been omitted. However Sunland Group Limited and its appointed agents disclaim all liability should any information or matter contained herein differ from the contract of sale or the actual constructed development. Images are illustrative only and all information is correct at the time of printing. © Sunland Group Limited. All rights reserved.

# THE LANES

RESIDENCES

## Type B2.1

LEVEL 3 - 11  
 UNIT 4307, 4407, 4507, 4607, 4707,  
 4807, 4907, 41007, 41107

INTERNAL	109m <sup>2</sup>
EXTERNAL	12m <sup>2</sup>
TOTAL AREA	121m <sup>2</sup>

01 ENTRY 02 LIVING 03 DINING  
 04 KITCHEN 05 PANTRY 06 BATHROOM  
 07 LAUNDRY 08 LINEN 09 BEDROOM  
 10 WALK-IN ROBE 11 ENSUITE 12 STUDY  
 13 BALCONY

0m  4m

### WEST VILLAGE KEY PLAN

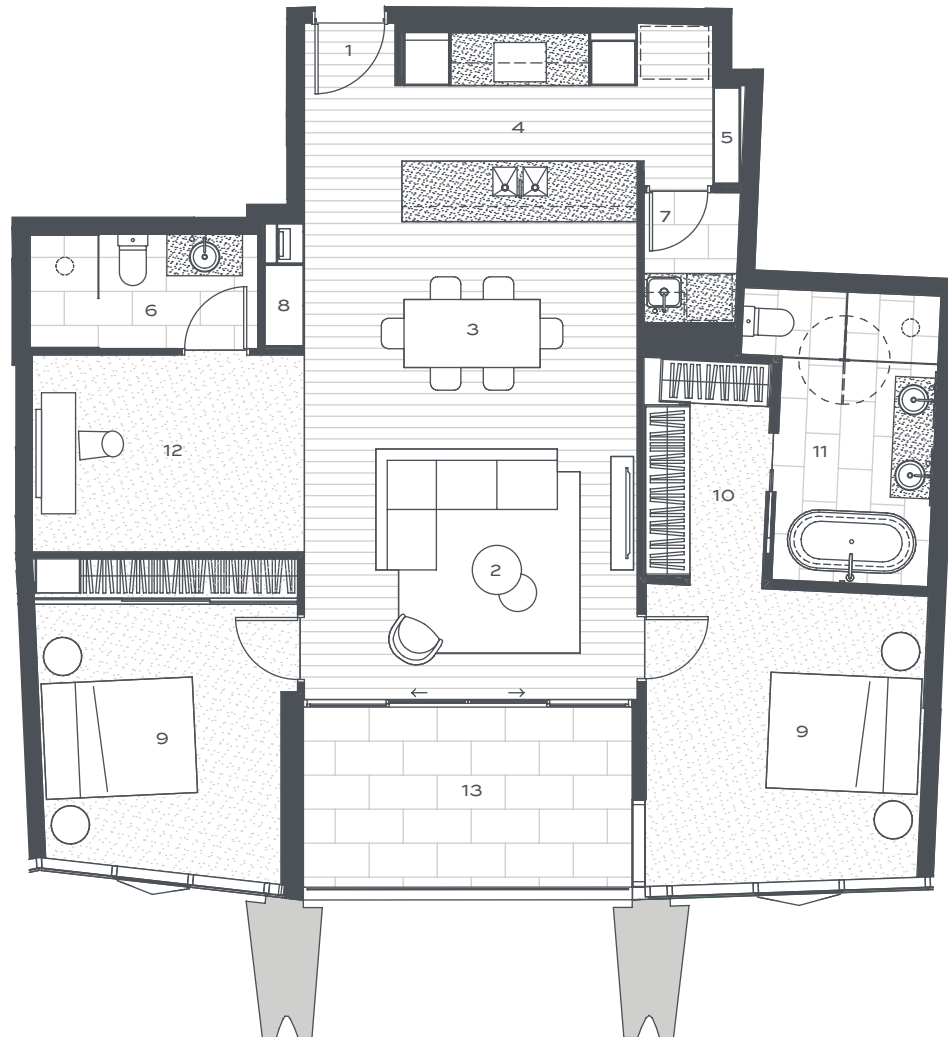
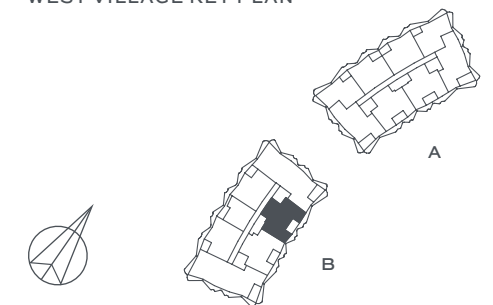

## Sunland Group

Indicative floor plan and artist impression only. Refer to the floor plans contained in the contract of sale for the actual floor plan as variations may apply. All floor areas measured to the centre of external walls and centre line of party walls. All external areas (patio and balconies) are included in the area calculation. External architectural features shown are indicative only. All reasonable care has been taken in the preparation of these floor plans. To the best of our knowledge, no relevant information has been omitted. However Sunland Group Limited and its appointed agents disclaim all liability should any information or matter contained herein differ from the contract of sale or the actual constructed development. Images are illustrative only and all information is correct at the time of printing. © Sunland Group Limited. All rights reserved.

# THE LANES

RESIDENCES

## Type B2.1

LEVEL 12  
UNIT 41207

INTERNAL	109m <sup>2</sup>
EXTERNAL	12m <sup>2</sup>
TOTAL AREA	121m <sup>2</sup>

01 ENTRY 02 LIVING 03 DINING  
04 KITCHEN 05 PANTRY 06 BATHROOM  
07 LAUNDRY 08 LINEN 09 BEDROOM  
10 WALK-IN ROBE 11 ENSUITE 12 STUDY  
13 BALCONY

0m  4m

WEST VILLAGE KEY PLAN

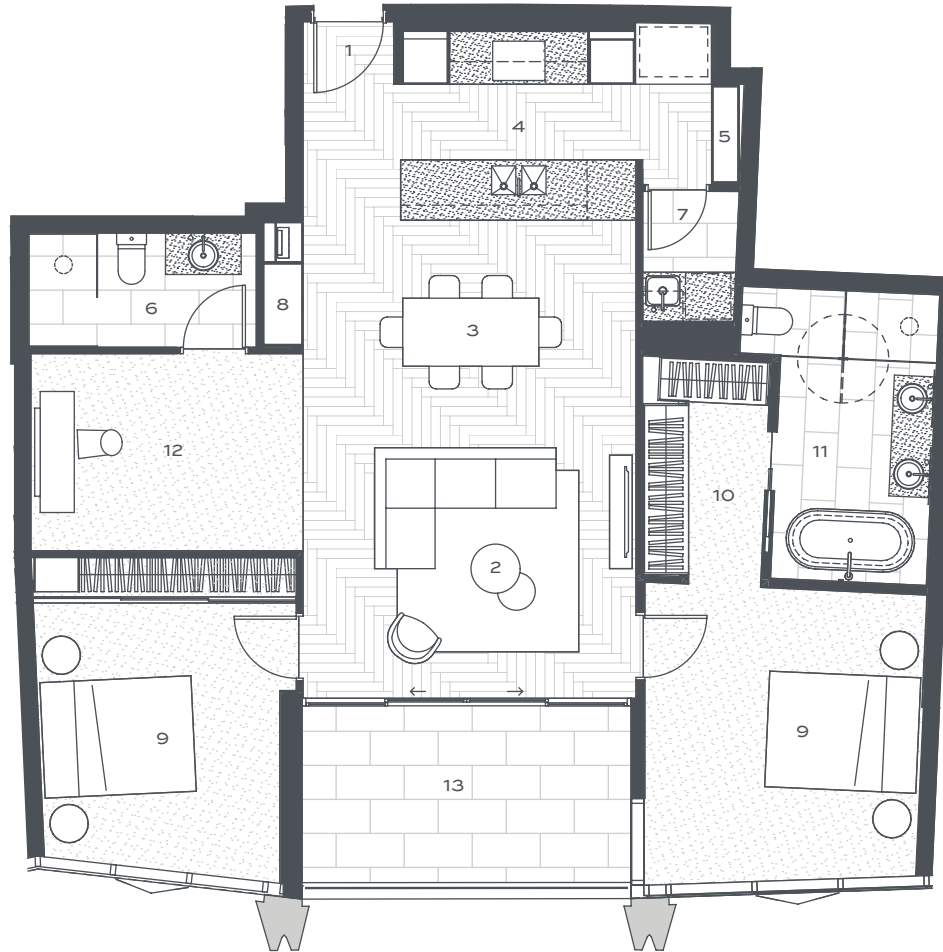
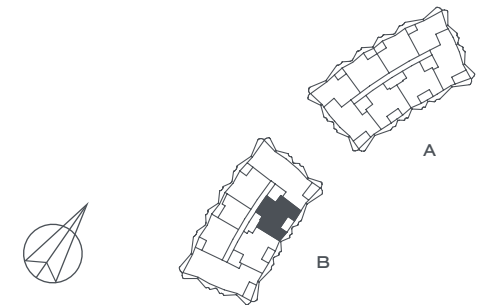

## Sunland Group

Indicative floor plan and artist impression only. Refer to the floor plans contained in the contract of sale for the actual floor plan as variations may apply. All floor areas measured to the centre of external walls and centre line of party walls. All external areas (patio and balconies) are included in the area calculation. External architectural features shown are indicative only. All reasonable care has been taken in the preparation of these floor plans. To the best of our knowledge, no relevant information has been omitted. However Sunland Group Limited and its appointed agents disclaim all liability should any information or matter contained herein differ from the contract of sale or the actual constructed development. Images are illustrative only and all information is correct at the time of printing. © Sunland Group Limited. All rights reserved.

# THE LANES

RESIDENCES

## Type B2.2

LEVEL 1 GROUND  
UNIT 4107

---

INTERNAL	112m <sup>2</sup>
EXTERNAL	41m <sup>2</sup>
TOTAL AREA	153m <sup>2</sup>

---

01 ENTRY 02 LIVING 03 DINING  
04 KITCHEN 05 PANTRY 06 BATHROOM  
07 LAUNDRY 08 LINEN 09 BEDROOM  
10 WALK-IN ROBE 11 ENSUITE 12 STUDY  
13 STORE 14 TERRACE 15 COURTYARD

---

0m  4m

WEST VILLAGE KEY PLAN

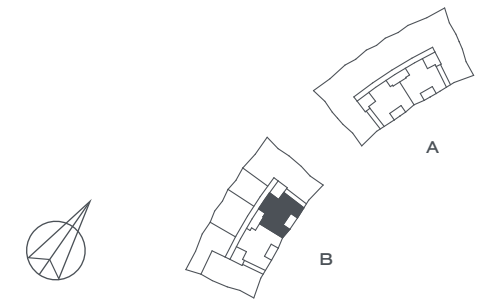

## Sunland Group

Indicative floor plan and artist impression only. Refer to the floor plans contained in the contract of sale for the actual floor plan as variations may apply. All floor areas measured to the centre of external walls and centre line of party walls. All external areas (patio and balconies) are included in the area calculation. External architectural features shown are indicative only. All reasonable care has been taken in the preparation of these floor plans. To the best of our knowledge, no relevant information has been omitted. However Sunland Group Limited and its appointed agents disclaim all liability should any information or matter contained herein differ from the contract of sale or the actual constructed development. Images are illustrative only and all information is correct at the time of printing. © Sunland Group Limited. All rights reserved.

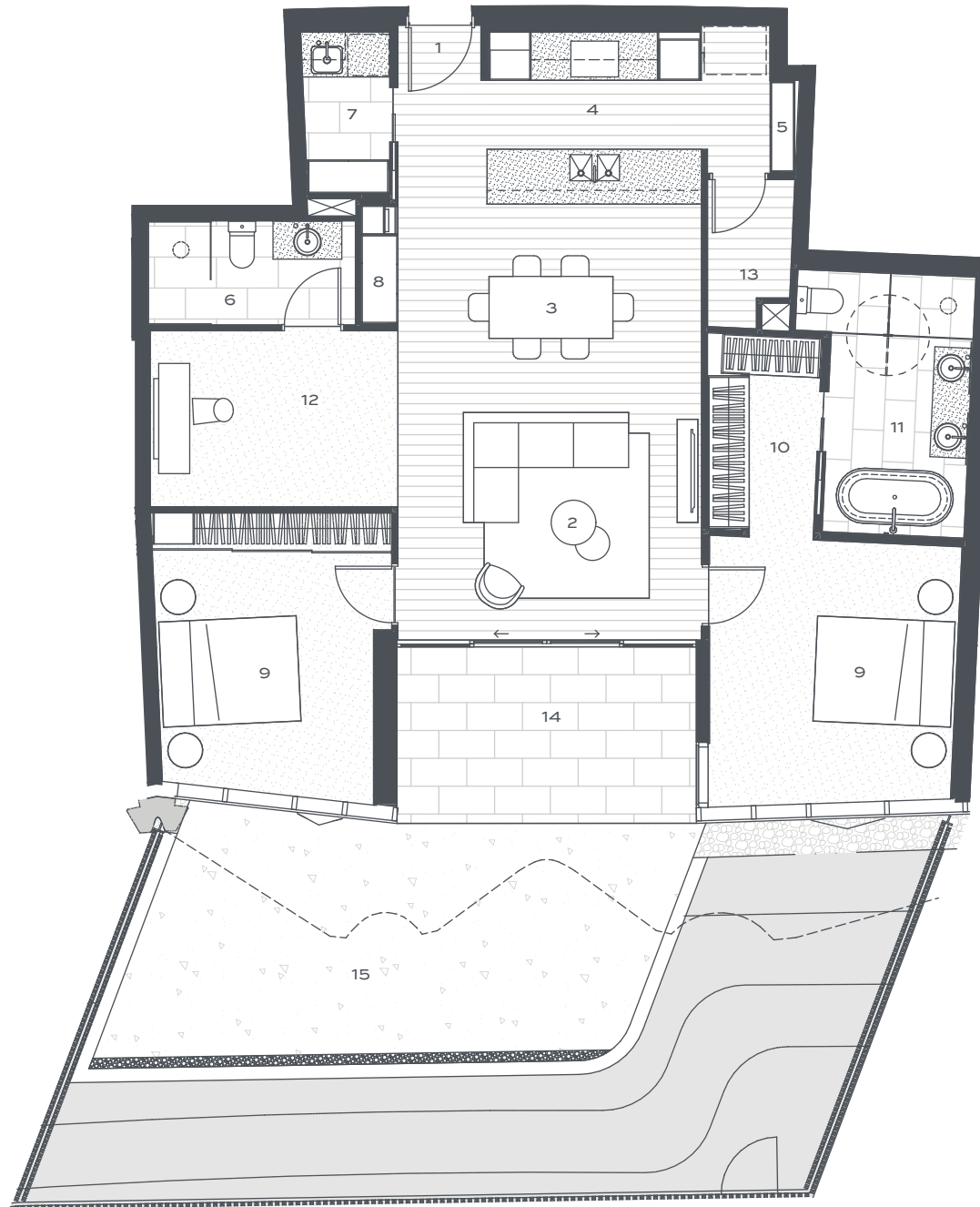



# THE LANES

RESIDENCES

## Type B2.3

LEVEL 1 GROUND  
UNIT 4101

INTERNAL	110m <sup>2</sup>
EXTERNAL	43m <sup>2</sup>
TOTAL AREA	153m <sup>2</sup>

01 ENTRY 02 LIVING 03 DINING  
04 KITCHEN 05 PANTRY 06 BATHROOM  
07 LAUNDRY 08 LINEN 09 BEDROOM  
10 WALK-IN ROBE 11 ENSUITE 12 STUDY  
13 TERRACE 14 COURTYARD

0m  4m

WEST VILLAGE KEY PLAN



## Sunland Group

Indicative floor plan and artist impression only. Refer to the floor plans contained in the contract of sale for the actual floor plan as variations may apply. All floor areas measured to the centre of external walls and centre line of party walls. All external areas (patio and balconies) are included in the area calculation. External architectural features shown are indicative only. All reasonable care has been taken in the preparation of these floor plans. To the best of our knowledge, no relevant information has been omitted. However Sunland Group Limited and its appointed agents disclaim all liability should any information or matter contained herein differ from the contract of sale or the actual constructed development. Images are illustrative only and all information is correct at the time of printing. © Sunland Group Limited. All rights reserved.

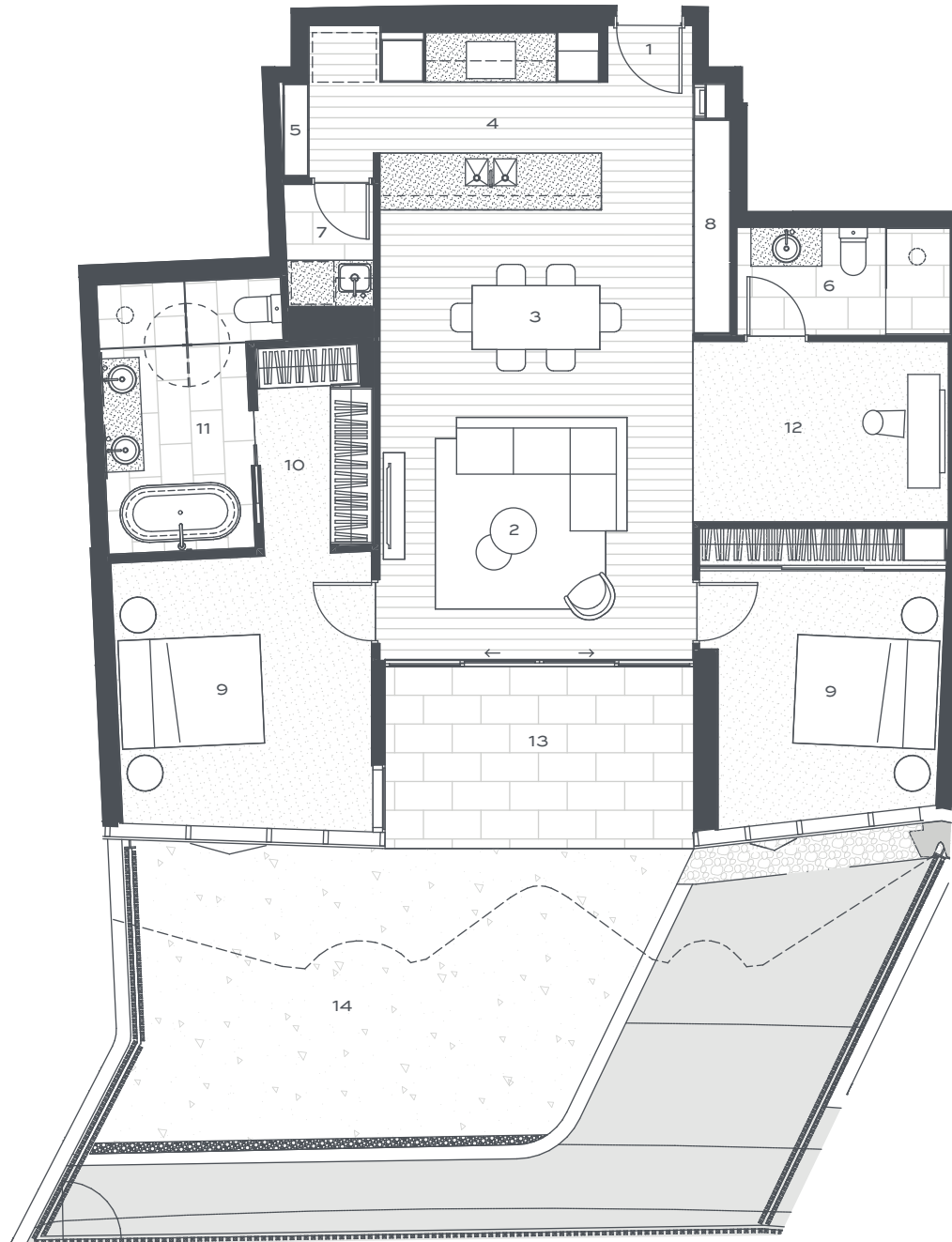

# THE LANES

RESIDENCES

## Type B2

LEVEL 2  
UNIT 4201

INTERNAL	110m <sup>2</sup>
EXTERNAL	12m <sup>2</sup>
TOTAL AREA	122m <sup>2</sup>

01 ENTRY 02 LIVING 03 DINING  
04 KITCHEN 05 PANTRY 06 BATHROOM  
07 LAUNDRY 08 LINEN 09 BEDROOM  
10 WALK-IN ROBE 11 ENSUITE 12 STUDY  
13 BALCONY

0m  4m

WEST VILLAGE KEY PLAN

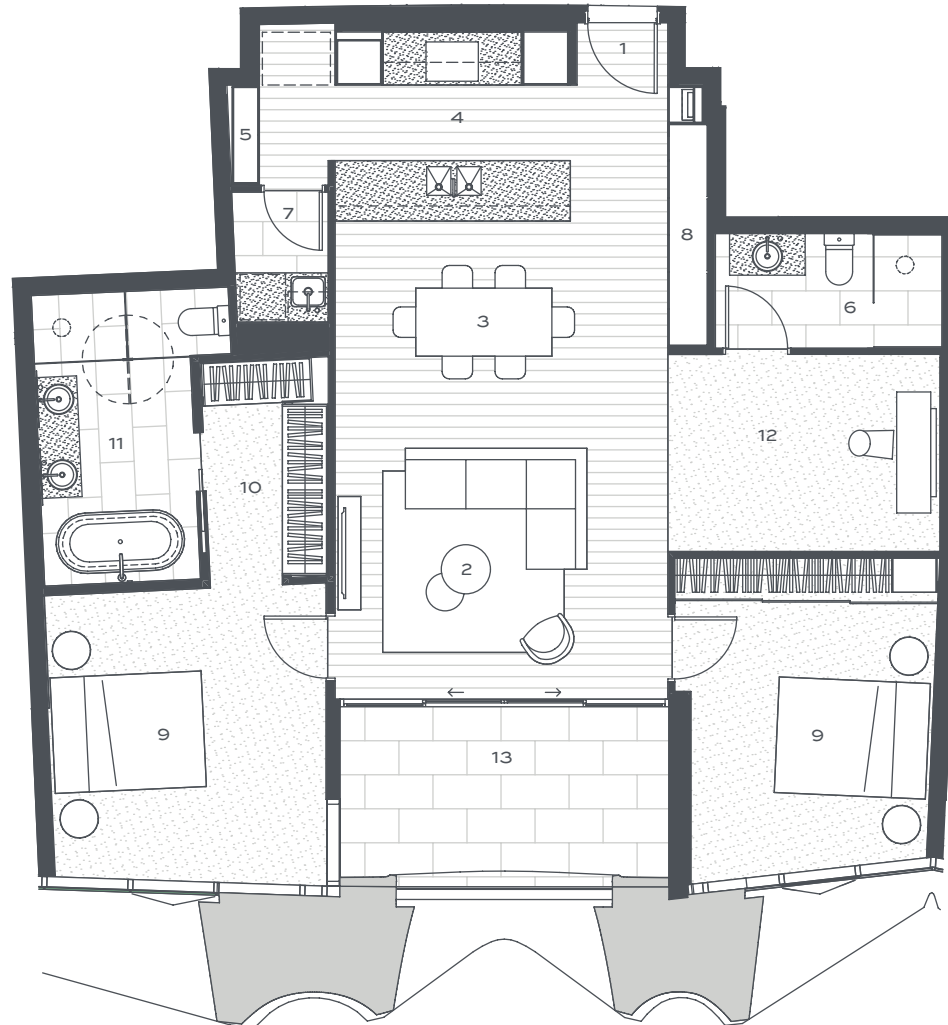
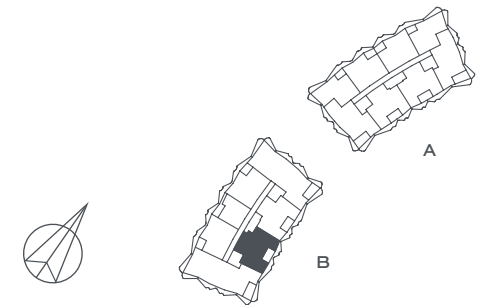

## Sunland Group

Indicative floor plan and artist impression only. Refer to the floor plans contained in the contract of sale for the actual floor plan as variations may apply. All floor areas measured to the centre of external walls and centre line of party walls. All external areas (patio and balconies) are included in the area calculation. External architectural features shown are indicative only. All reasonable care has been taken in the preparation of these floor plans. To the best of our knowledge, no relevant information has been omitted. However Sunland Group Limited and its appointed agents disclaim all liability should any information or matter contained herein differ from the contract of sale or the actual constructed development. Images are illustrative only and all information is correct at the time of printing. © Sunland Group Limited. All rights reserved.

# THE LANES

RESIDENCES

## Type B2

LEVEL 3 - 11

UNIT 4301, 4401, 4501, 4601, 4701,  
4801, 4901, 41001, 41101

INTERNAL	110m <sup>2</sup>
EXTERNAL	12m <sup>2</sup>
TOTAL AREA	122m <sup>2</sup>

01 ENTRY 02 LIVING 03 DINING  
04 KITCHEN 05 PANTRY 06 BATHROOM  
07 LAUNDRY 08 LINEN 09 BEDROOM  
10 WALK-IN ROBE 11 ENSUITE 12 STUDY  
13 BALCONY

0m 4m

WEST VILLAGE KEY PLAN

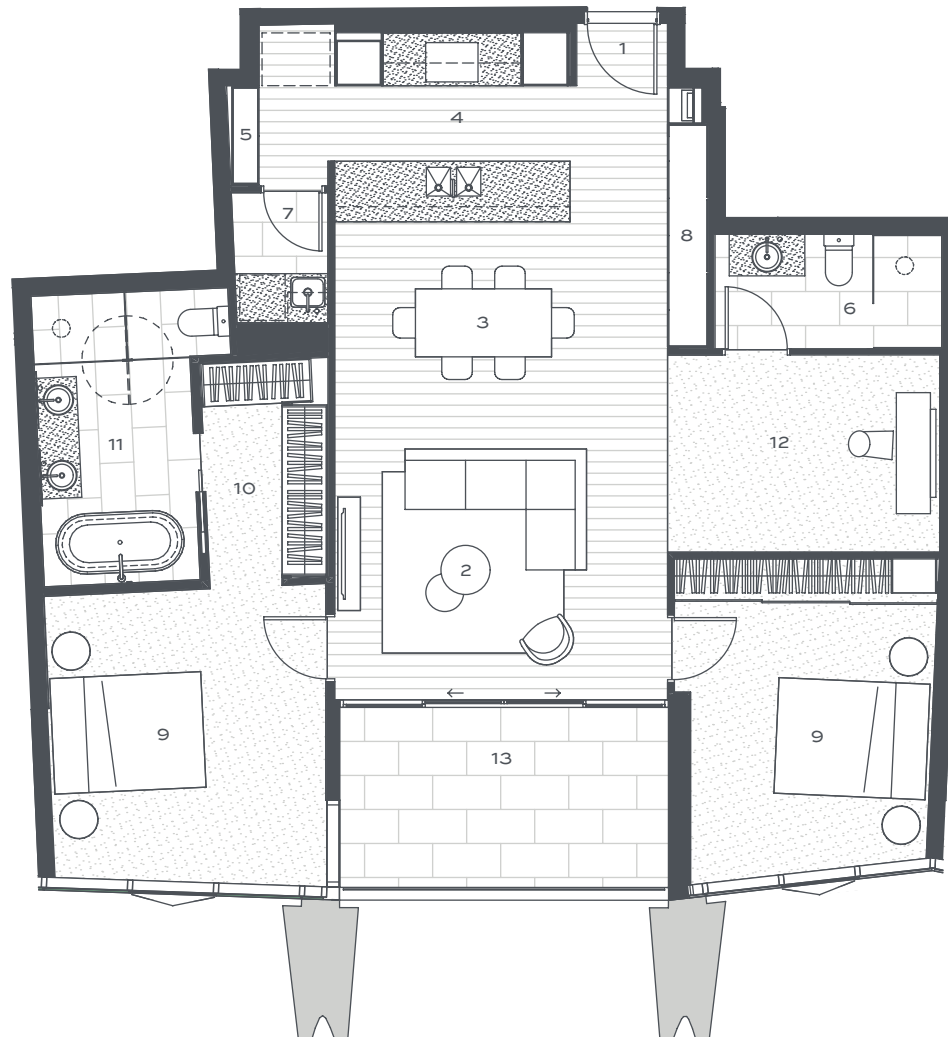
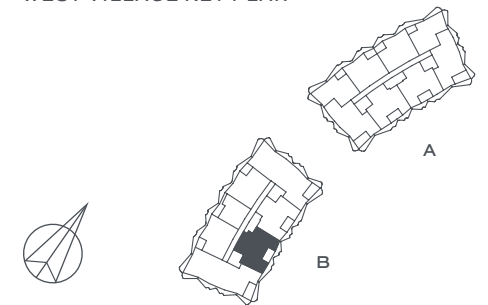

## Sunland Group

Indicative floor plan and artist impression only. Refer to the floor plans contained in the contract of sale for the actual floor plan as variations may apply. All floor areas measured to the centre of external walls and centre line of party walls. All external areas (patio and balconies) are included in the area calculation. External architectural features shown are indicative only. All reasonable care has been taken in the preparation of these floor plans. To the best of our knowledge, no relevant information has been omitted. However Sunland Group Limited and its appointed agents disclaim all liability should any information or matter contained herein differ from the contract of sale or the actual constructed development. Images are illustrative only and all information is correct at the time of printing. © Sunland Group Limited. All rights reserved.

# THE LANES

RESIDENCES

## Type B2

LEVEL 12  
UNIT 41201

---

INTERNAL	110m <sup>2</sup>
EXTERNAL	12m <sup>2</sup>
TOTAL AREA	122m <sup>2</sup>

---

01 ENTRY 02 LIVING 03 DINING  
04 KITCHEN 05 PANTRY 06 BATHROOM  
07 LAUNDRY 08 LINEN 09 BEDROOM  
10 WALK-IN ROBE 11 ENSUITE 12 STUDY  
13 BALCONY

---

0m  4m

WEST VILLAGE KEY PLAN

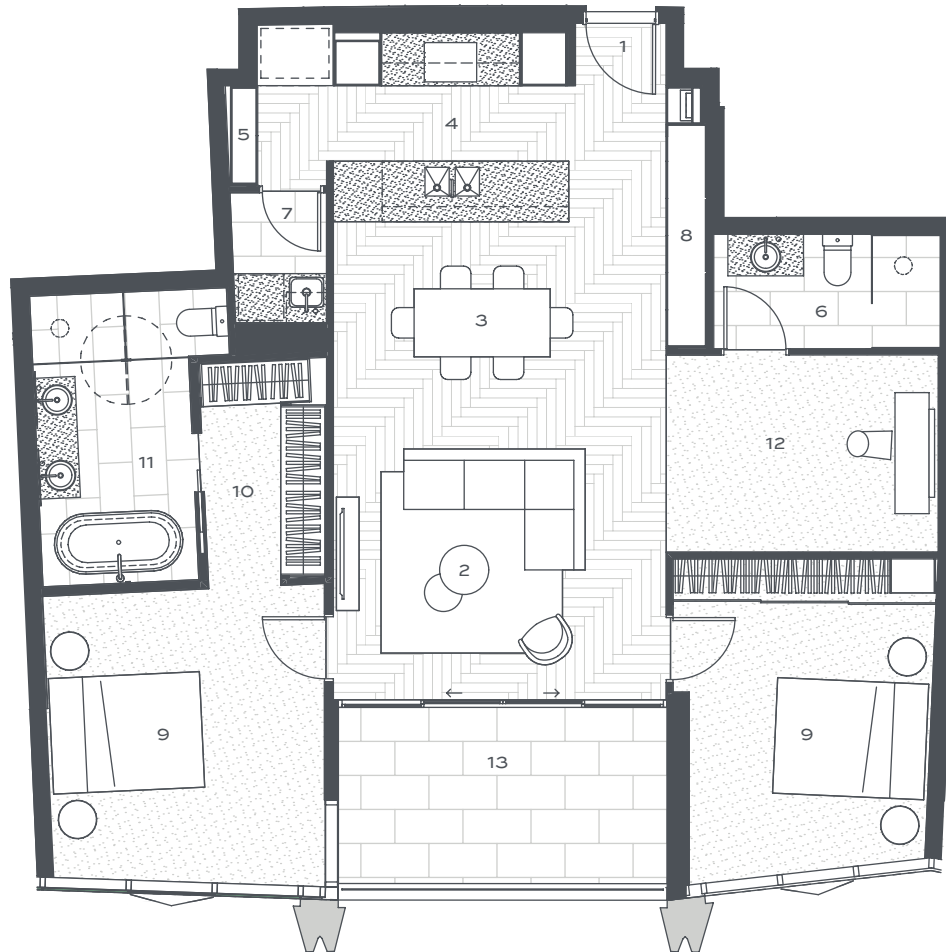
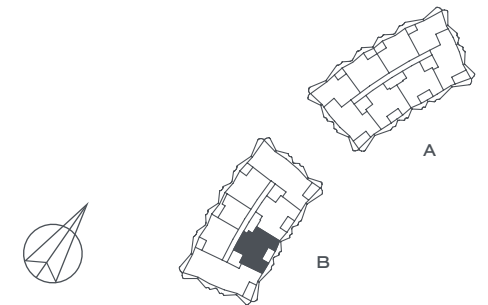

## Sunland Group

Indicative floor plan and artist impression only. Refer to the floor plans contained in the contract of sale for the actual floor plan as variations may apply. All floor areas measured to the centre of external walls and centre line of party walls. All external areas (patio and balconies) are included in the area calculation. External architectural features shown are indicative only. All reasonable care has been taken in the preparation of these floor plans. To the best of our knowledge, no relevant information has been omitted. However Sunland Group Limited and its appointed agents disclaim all liability should any information or matter contained herein differ from the contract of sale or the actual constructed development. Images are illustrative only and all information is correct at the time of printing. © Sunland Group Limited. All rights reserved.

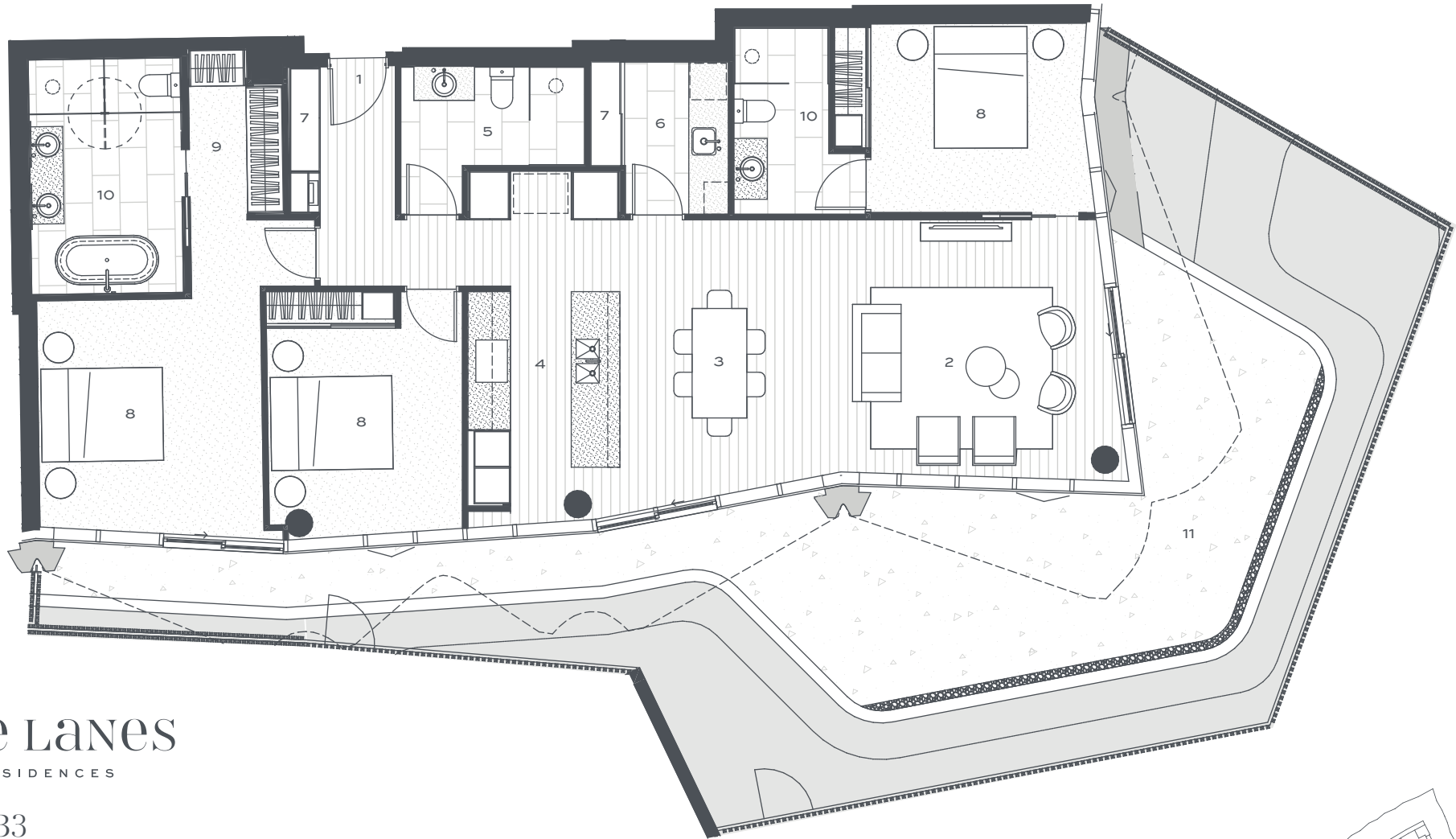

# THE LANES

RESIDENCES

## Type B3

LEVEL 1 GROUND

UNIT 4102

INTERNAL 140m<sup>2</sup>

EXTERNAL 50m<sup>2</sup>

TOTAL AREA 190m<sup>2</sup>

0m 4m



WEST VILLAGE KEY PLAN

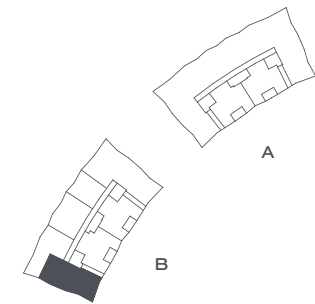

01 ENTRY 02 LIVING 03 DINING 04 KITCHEN 05 BATHROOM 06 LAUNDRY 07 LINEN 08 BEDROOM 09 WALK-IN ROBE 10 ENSUITE 11 COURTYARD

Indicative floor plan and artist impression only. Refer to the floor plans contained in the contract of sale for the actual floor plan as variations may apply. All floor areas measured to the centre of external walls and centre line of party walls. All external areas (patio and balconies) are included in the area calculation. External architectural features shown are indicative only. All reasonable care has been taken in the preparation of these floor plans. To the best of our knowledge, no relevant information has been omitted. However Sunland Group Limited and its appointed agents disclaim all liability should any information or matter contained herein differ from the contract of sale or the actual constructed development. Images are illustrative only and all information is correct at the time of printing. © Sunland Group Limited. All rights reserved.

# THE LANES

RESIDENCES

## Type B4.m

LEVEL 2

UNIT 4205

---

INTERNAL	95m <sup>2</sup>
EXTERNAL	9m <sup>2</sup>
TOTAL AREA	104m <sup>2</sup>

---

01 ENTRY 02 LIVING 03 DINING  
04 KITCHEN 05 BATHROOM 06 LAUNDRY  
07 LINEN 08 BEDROOM 09 WALK-IN ROBE  
10 ENSUITE 11 STUDY 12 BALCONY

---

0m  4m

### WEST VILLAGE KEY PLAN

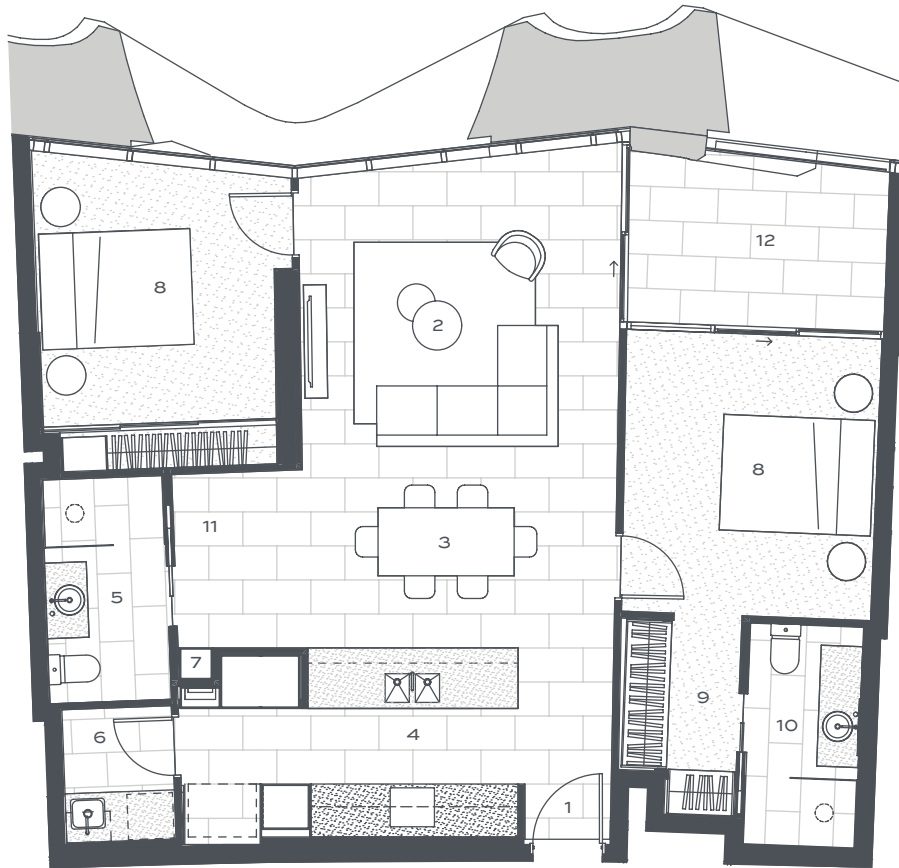
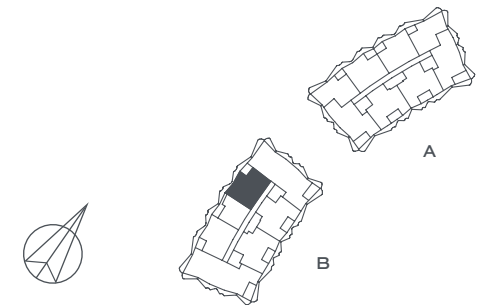

## Sunland Group

Indicative floor plan and artist impression only. Refer to the floor plans contained in the contract of sale for the actual floor plan as variations may apply. All floor areas measured to the centre of external walls and centre line of party walls. All external areas (patio and balconies) are included in the area calculation. External architectural features shown are indicative only. All reasonable care has been taken in the preparation of these floor plans. To the best of our knowledge, no relevant information has been omitted. However Sunland Group Limited and its appointed agents disclaim all liability should any information or matter contained herein differ from the contract of sale or the actual constructed development. Images are illustrative only and all information is correct at the time of printing. © Sunland Group Limited. All rights reserved.

# THE LANES

RESIDENCES

## Type B4.m

LEVEL 3 - 11

UNIT 4305, 4405, 4505, 4605, 4705,  
4805, 4905, 41005, 41105

---

INTERNAL	95m <sup>2</sup>
EXTERNAL	9m <sup>2</sup>
TOTAL AREA	104m <sup>2</sup>

---

01 ENTRY 02 LIVING 03 DINING  
04 KITCHEN 05 BATHROOM 06 LAUNDRY  
07 LINEN 08 BEDROOM 09 WALK-IN ROBE  
10 ENSUITE 11 STUDY 12 BALCONY

---

0m  4m

WEST VILLAGE KEY PLAN

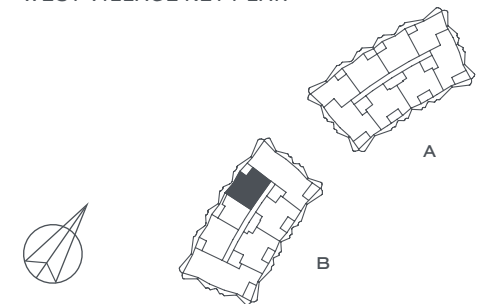

## Sunland Group

Indicative floor plan and artist impression only. Refer to the floor plans contained in the contract of sale for the actual floor plan as variations may apply. All floor areas measured to the centre of external walls and centre line of party walls. All external areas (patio and balconies) are included in the area calculation. External architectural features shown are indicative only. All reasonable care has been taken in the preparation of these floor plans. To the best of our knowledge, no relevant information has been omitted. However Sunland Group Limited and its appointed agents disclaim all liability should any information or matter contained herein differ from the contract of sale or the actual constructed development. Images are illustrative only and all information is correct at the time of printing. © Sunland Group Limited. All rights reserved.

# THE LANES

RESIDENCES

## Type B4.m

LEVEL 12

UNIT 41205

---

INTERNAL	95m <sup>2</sup>
EXTERNAL	9m <sup>2</sup>
TOTAL AREA	104m <sup>2</sup>

---

01 ENTRY 02 LIVING 03 DINING  
04 KITCHEN 05 BATHROOM 06 LAUNDRY  
07 LINEN 08 BEDROOM 09 WALK-IN ROBE  
10 ENSUITE 11 STUDY 12 BALCONY

---

0m  4m

WEST VILLAGE KEY PLAN

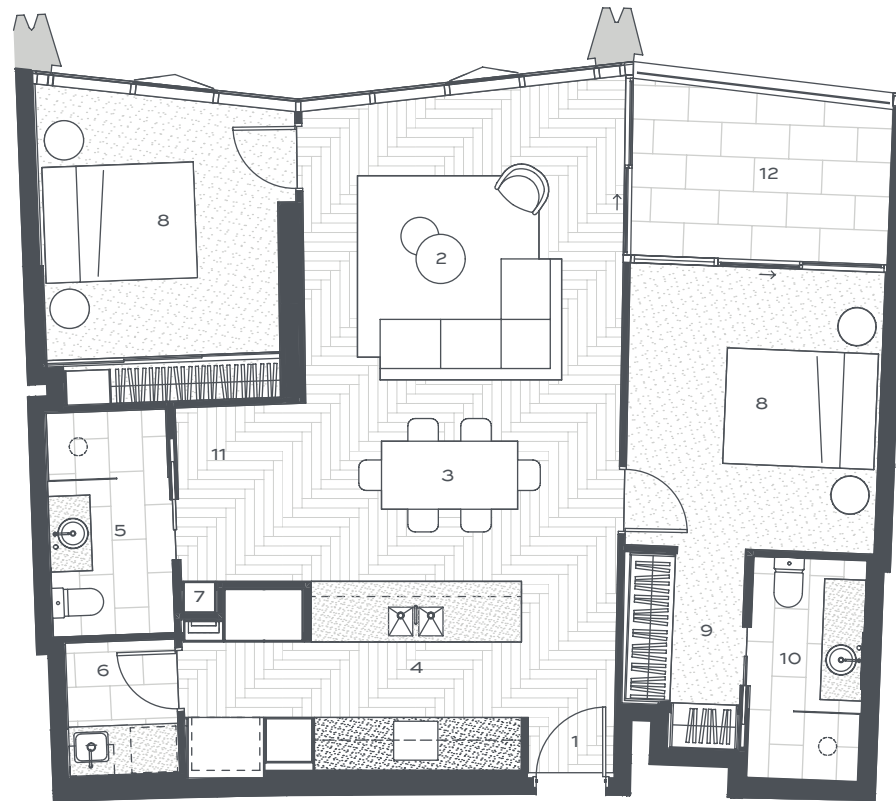
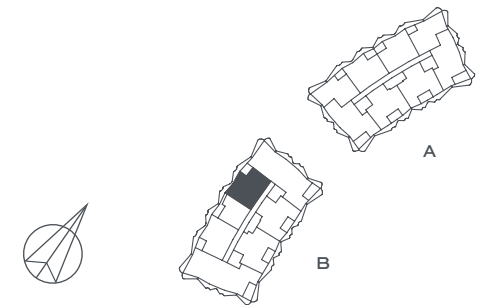

## Sunland Group

Indicative floor plan and artist impression only. Refer to the floor plans contained in the contract of sale for the actual floor plan as variations may apply. All floor areas measured to the centre of external walls and centre line of party walls. All external areas (patio and balconies) are included in the area calculation. External architectural features shown are indicative only. All reasonable care has been taken in the preparation of these floor plans. To the best of our knowledge, no relevant information has been omitted. However Sunland Group Limited and its appointed agents disclaim all liability should any information or matter contained herein differ from the contract of sale or the actual constructed development. Images are illustrative only and all information is correct at the time of printing. © Sunland Group Limited. All rights reserved.



# THE LANES

RESIDENCES

## Type B4

LEVEL 2

UNIT 4203

---

INTERNAL	95m <sup>2</sup>
EXTERNAL	9m <sup>2</sup>
TOTAL AREA	104m <sup>2</sup>

---

01 ENTRY 02 LIVING 03 DINING  
04 KITCHEN 05 BATHROOM 06 LAUNDRY  
07 LINEN 08 BEDROOM 09 WALK-IN ROBE  
10 ENSUITE 11 STUDY 12 BALCONY

---

0m  4m

### WEST VILLAGE KEY PLAN

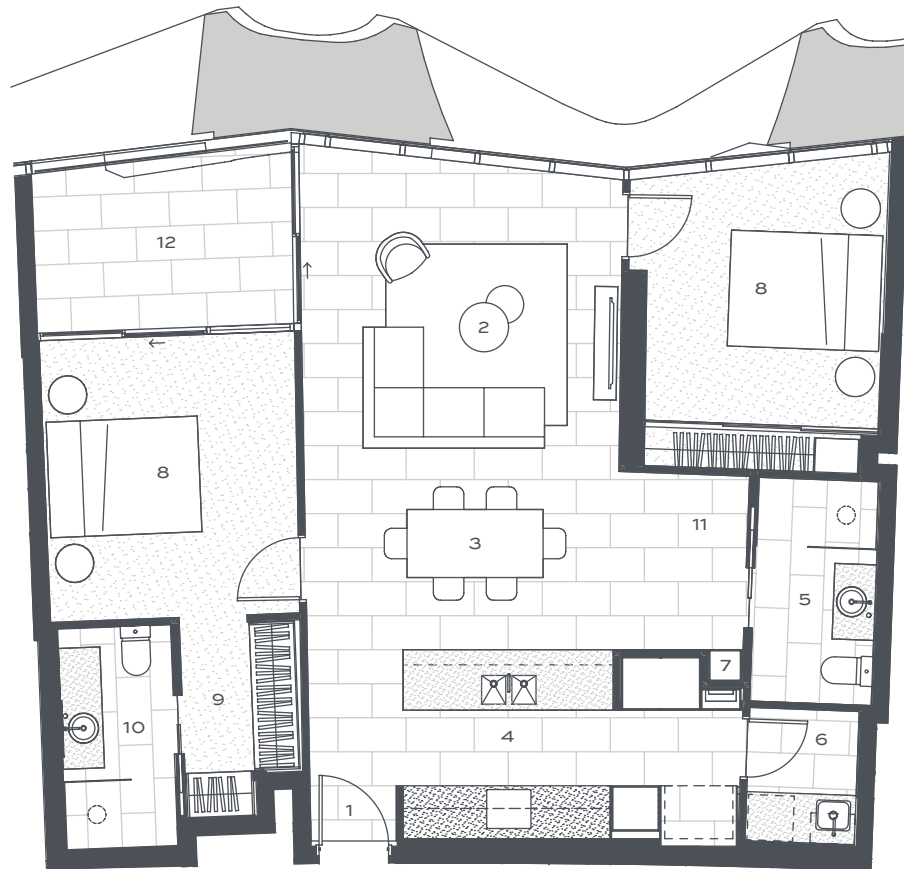
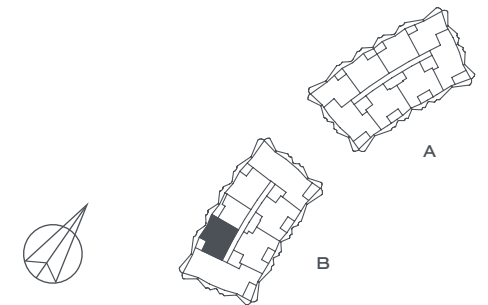

## Sunland Group

Indicative floor plan and artist impression only. Refer to the floor plans contained in the contract of sale for the actual floor plan as variations may apply. All floor areas measured to the centre of external walls and centre line of party walls. All external areas (patio and balconies) are included in the area calculation. External architectural features shown are indicative only. All reasonable care has been taken in the preparation of these floor plans. To the best of our knowledge, no relevant information has been omitted. However Sunland Group Limited and its appointed agents disclaim all liability should any information or matter contained herein differ from the contract of sale or the actual constructed development. Images are illustrative only and all information is correct at the time of printing. © Sunland Group Limited. All rights reserved.

# THE LANES

RESIDENCES

## Type B4

LEVEL 3 - 11

UNIT 4303, 4403, 4503, 4603, 4703,  
4803, 4903, 41003, 41103

---

INTERNAL	95m <sup>2</sup>
EXTERNAL	9m <sup>2</sup>
TOTAL AREA	104m <sup>2</sup>

---

01 ENTRY 02 LIVING 03 DINING  
04 KITCHEN 05 BATHROOM 06 LAUNDRY  
07 LINEN 08 BEDROOM 09 WALK-IN ROBE  
10 ENSUITE 11 STUDY 12 BALCONY

---

0m  4m

WEST VILLAGE KEY PLAN

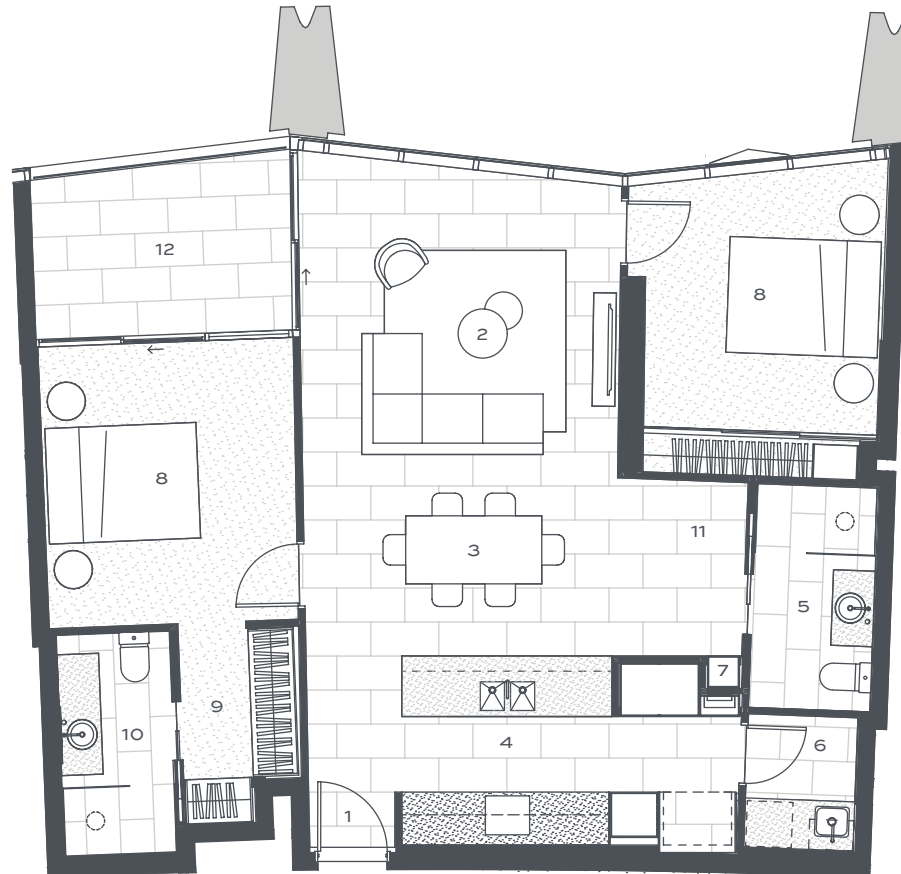
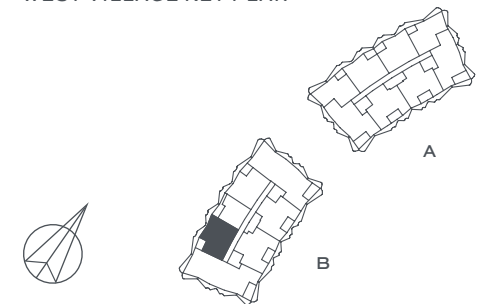

## Sunland Group

Indicative floor plan and artist impression only. Refer to the floor plans contained in the contract of sale for the actual floor plan as variations may apply. All floor areas measured to the centre of external walls and centre line of party walls. All external areas (patio and balconies) are included in the area calculation. External architectural features shown are indicative only. All reasonable care has been taken in the preparation of these floor plans. To the best of our knowledge, no relevant information has been omitted. However Sunland Group Limited and its appointed agents disclaim all liability should any information or matter contained herein differ from the contract of sale or the actual constructed development. Images are illustrative only and all information is correct at the time of printing. © Sunland Group Limited. All rights reserved.

# THE LANES

RESIDENCES

## Type B4

LEVEL 12

UNIT 41203

---

INTERNAL	95m <sup>2</sup>
EXTERNAL	9m <sup>2</sup>
TOTAL AREA	104m <sup>2</sup>

---

01 ENTRY 02 LIVING 03 DINING  
04 KITCHEN 05 BATHROOM 06 LAUNDRY  
07 LINEN 08 BEDROOM 09 WALK-IN ROBE  
10 ENSUITE 11 STUDY 12 BALCONY

---

0m  4m

WEST VILLAGE KEY PLAN

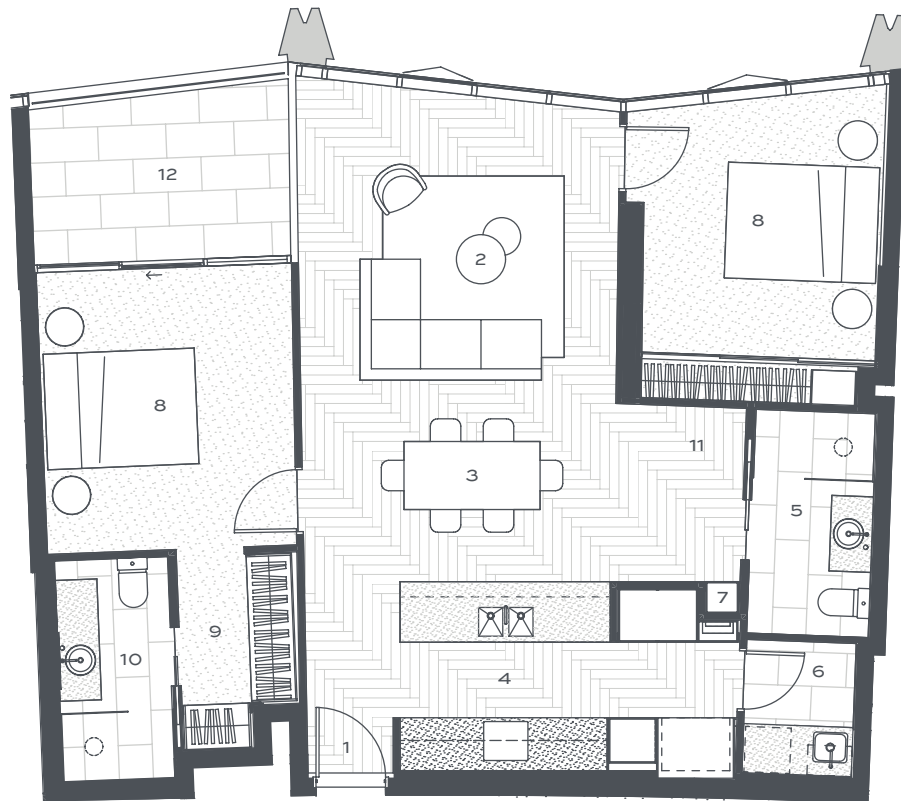
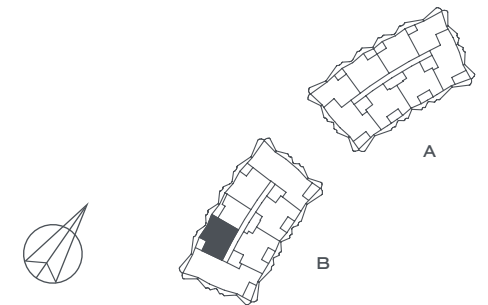

## Sunland Group

Indicative floor plan and artist impression only. Refer to the floor plans contained in the contract of sale for the actual floor plan as variations may apply. All floor areas measured to the centre of external walls and centre line of party walls. All external areas (patio and balconies) are included in the area calculation. External architectural features shown are indicative only. All reasonable care has been taken in the preparation of these floor plans. To the best of our knowledge, no relevant information has been omitted. However Sunland Group Limited and its appointed agents disclaim all liability should any information or matter contained herein differ from the contract of sale or the actual constructed development. Images are illustrative only and all information is correct at the time of printing. © Sunland Group Limited. All rights reserved.

# THE LANES

RESIDENCES

## Type B5

LEVEL 1 GROUND

UNIT 4104

---

INTERNAL	105m <sup>2</sup>
EXTERNAL	18m <sup>2</sup>
TOTAL AREA	123m <sup>2</sup>

---

01 ENTRY 02 LIVING 03 DINING  
04 KITCHEN 05 BATHROOM 06 LAUNDRY  
07 LINEN 08 BEDROOM 09 WALK-IN ROBE  
10 ENSUITE 11 STUDY 12 COURTYARD

---

0m  4m

WEST VILLAGE KEY PLAN

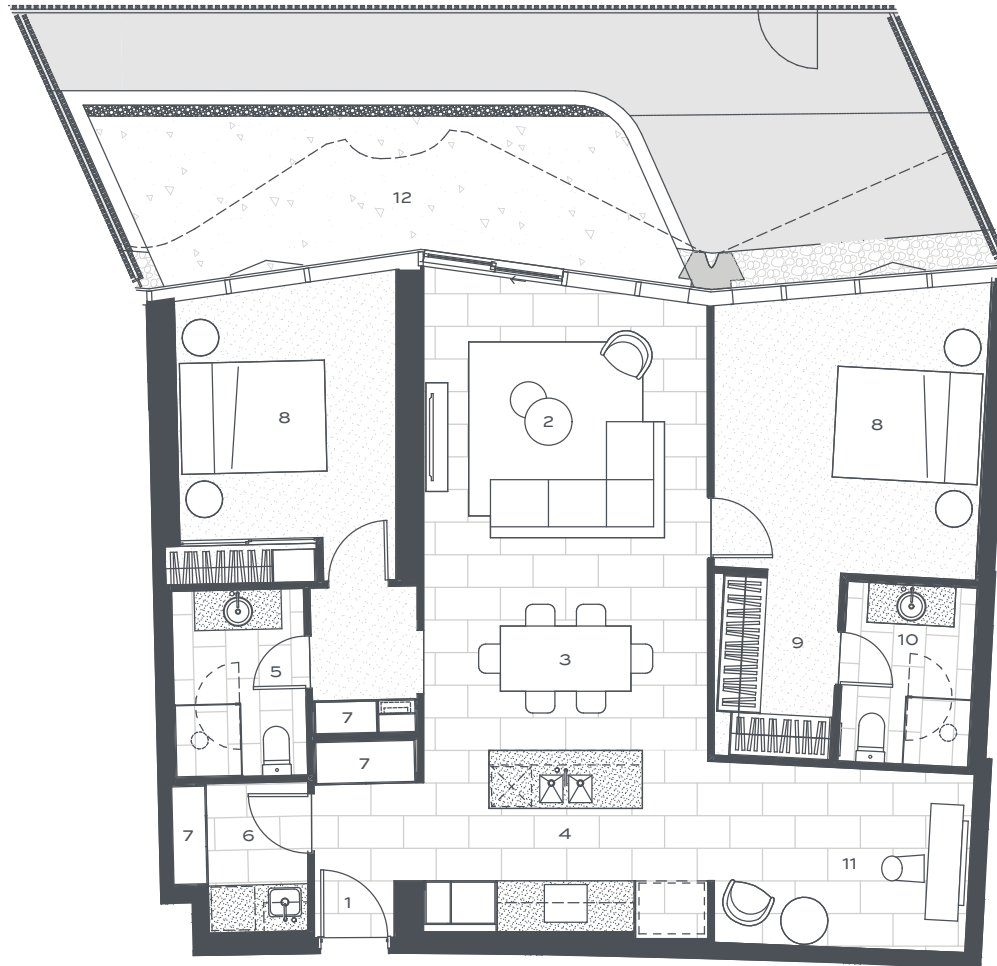
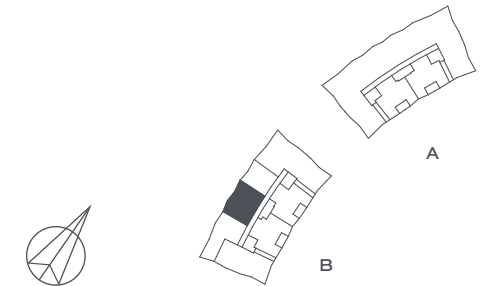

## Sunland Group

Indicative floor plan and artist impression only. Refer to the floor plans contained in the contract of sale for the actual floor plan as variations may apply. All floor areas measured to the centre of external walls and centre line of party walls. All external areas (patio and balconies) are included in the area calculation. External architectural features shown are indicative only. All reasonable care has been taken in the preparation of these floor plans. To the best of our knowledge, no relevant information has been omitted. However Sunland Group Limited and its appointed agents disclaim all liability should any information or matter contained herein differ from the contract of sale or the actual constructed development. Images are illustrative only and all information is correct at the time of printing. © Sunland Group Limited. All rights reserved.

# THE LANES

RESIDENCES

## Type B6

LEVEL 2

UNIT 4204

---

INTERNAL	61m <sup>2</sup>
EXTERNAL	12m <sup>2</sup>
TOTAL AREA	73m <sup>2</sup>

---

01 ENTRY 02 LIVING 03 DINING  
04 KITCHEN 05 BATHROOM 06 LAUNDRY  
07 LINEN 08 BEDROOM 09 BALCONY

---

0m  4m

WEST VILLAGE KEY PLAN

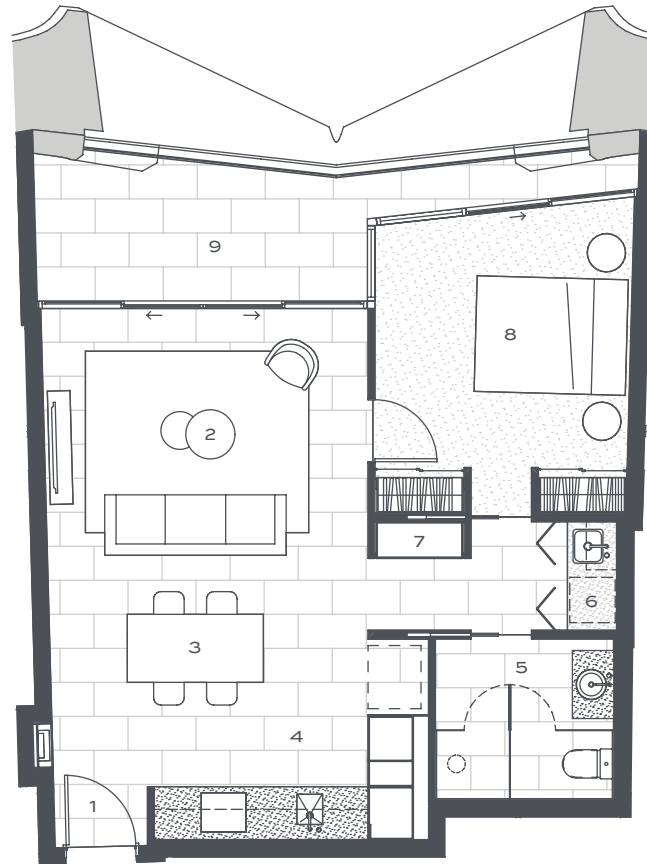
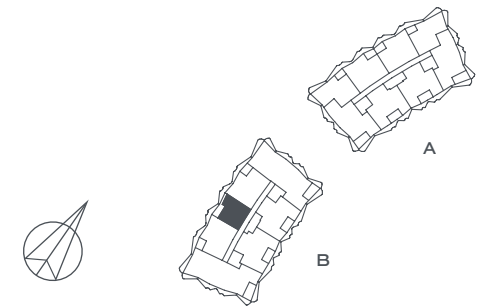

## Sunland Group

Indicative floor plan and artist impression only. Refer to the floor plans contained in the contract of sale for the actual floor plan as variations may apply. All floor areas measured to the centre of external walls and centre line of party walls. All external areas (patio and balconies) are included in the area calculation. External architectural features shown are indicative only. All reasonable care has been taken in the preparation of these floor plans. To the best of our knowledge, no relevant information has been omitted. However Sunland Group Limited and its appointed agents disclaim all liability should any information or matter contained herein differ from the contract of sale or the actual constructed development. Images are illustrative only and all information is correct at the time of printing. © Sunland Group Limited. All rights reserved.

# THE LANES

RESIDENCES

## Type B6

LEVEL 3 - 11

UNIT 4304, 4404, 4504, 4604, 4704,  
4804, 4904, 41004, 41104

---

INTERNAL	61m <sup>2</sup>
EXTERNAL	12m <sup>2</sup>
TOTAL AREA	73m <sup>2</sup>

---

01 ENTRY 02 LIVING 03 DINING  
04 KITCHEN 05 BATHROOM 06 LAUNDRY  
07 LINEN 08 BEDROOM 09 BALCONY

---

0m  4m

WEST VILLAGE KEY PLAN

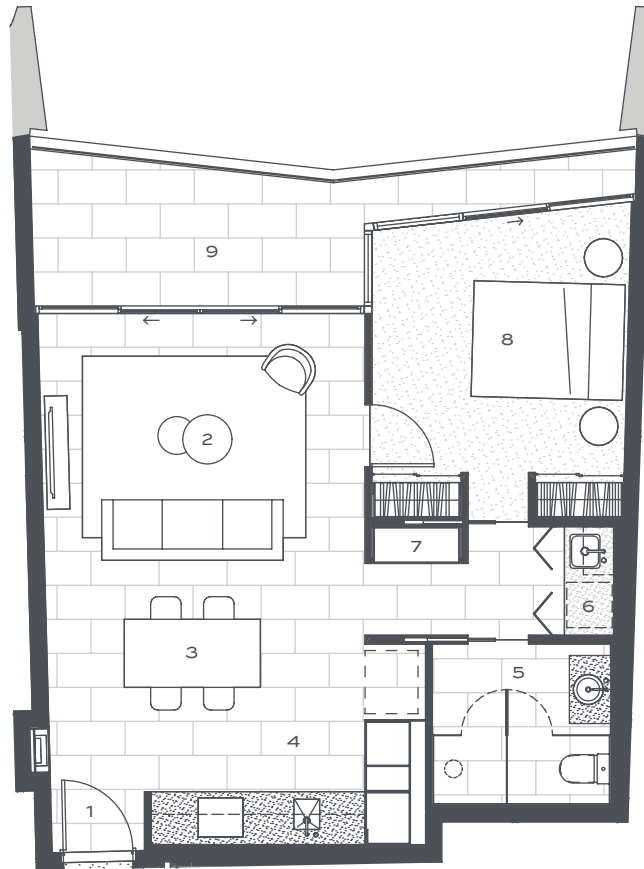
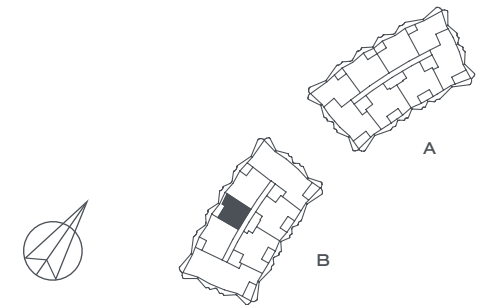

## Sunland Group

Indicative floor plan and artist impression only. Refer to the floor plans contained in the contract of sale for the actual floor plan as variations may apply. All floor areas measured to the centre of external walls and centre line of party walls. All external areas (patio and balconies) are included in the area calculation. External architectural features shown are indicative only. All reasonable care has been taken in the preparation of these floor plans. To the best of our knowledge, no relevant information has been omitted. However Sunland Group Limited and its appointed agents disclaim all liability should any information or matter contained herein differ from the contract of sale or the actual constructed development. Images are illustrative only and all information is correct at the time of printing. © Sunland Group Limited. All rights reserved.

# THE LANES

RESIDENCES

## Type B6

LEVEL 12

UNIT 41204

---

INTERNAL	61m <sup>2</sup>
EXTERNAL	12m <sup>2</sup>
TOTAL AREA	73m <sup>2</sup>

---

01 ENTRY 02 LIVING 03 DINING  
04 KITCHEN 05 BATHROOM 06 LAUNDRY  
07 LINEN 08 BEDROOM 09 BALCONY

---

0m  4m

WEST VILLAGE KEY PLAN

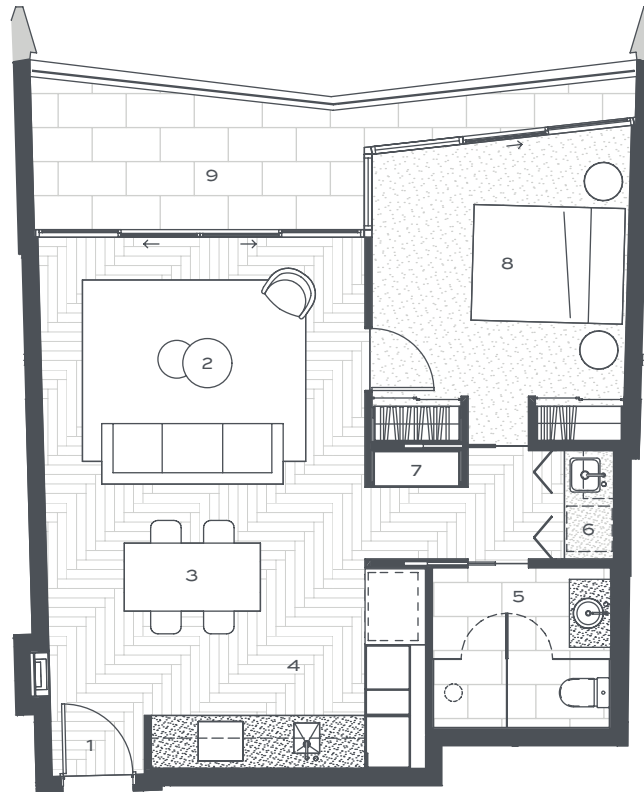
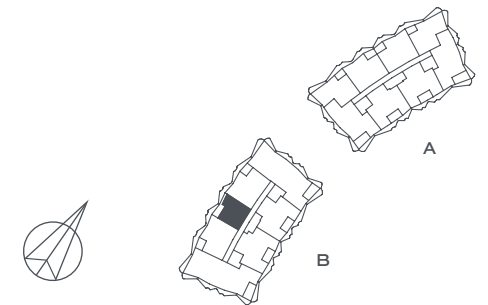

## Sunland Group

Indicative floor plan and artist impression only. Refer to the floor plans contained in the contract of sale for the actual floor plan as variations may apply. All floor areas measured to the centre of external walls and centre line of party walls. All external areas (patio and balconies) are included in the area calculation. External architectural features shown are indicative only. All reasonable care has been taken in the preparation of these floor plans. To the best of our knowledge, no relevant information has been omitted. However Sunland Group Limited and its appointed agents disclaim all liability should any information or matter contained herein differ from the contract of sale or the actual constructed development. Images are illustrative only and all information is correct at the time of printing. © Sunland Group Limited. All rights reserved.

# THE LANES

RESIDENCES

## Type B7

LEVEL 1 GROUND

UNIT 4105

---

INTERNAL	70m <sup>2</sup>
EXTERNAL	19m <sup>2</sup>
TOTAL AREA	89m <sup>2</sup>

---

01 ENTRY 02 LIVING 03 DINING  
04 KITCHEN 05 BATHROOM 06 LAUNDRY  
07 LINEN 08 BEDROOM 09 COURTYARD

---

0m  4m

WEST VILLAGE KEY PLAN

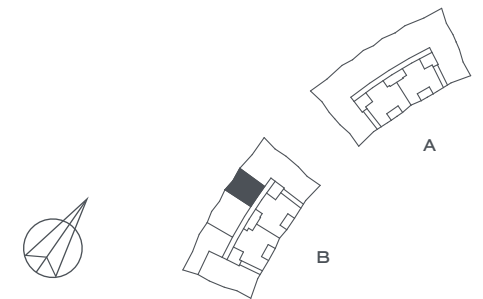

## Sunland Group

Indicative floor plan and artist impression only. Refer to the floor plans contained in the contract of sale for the actual floor plan as variations may apply. All floor areas measured to the centre of external walls and centre line of party walls. All external areas (patio and balconies) are included in the area calculation. External architectural features shown are indicative only. All reasonable care has been taken in the preparation of these floor plans. To the best of our knowledge, no relevant information has been omitted. However Sunland Group Limited and its appointed agents disclaim all liability should any information or matter contained herein differ from the contract of sale or the actual constructed development. Images are illustrative only and all information is correct at the time of printing. © Sunland Group Limited. All rights reserved.

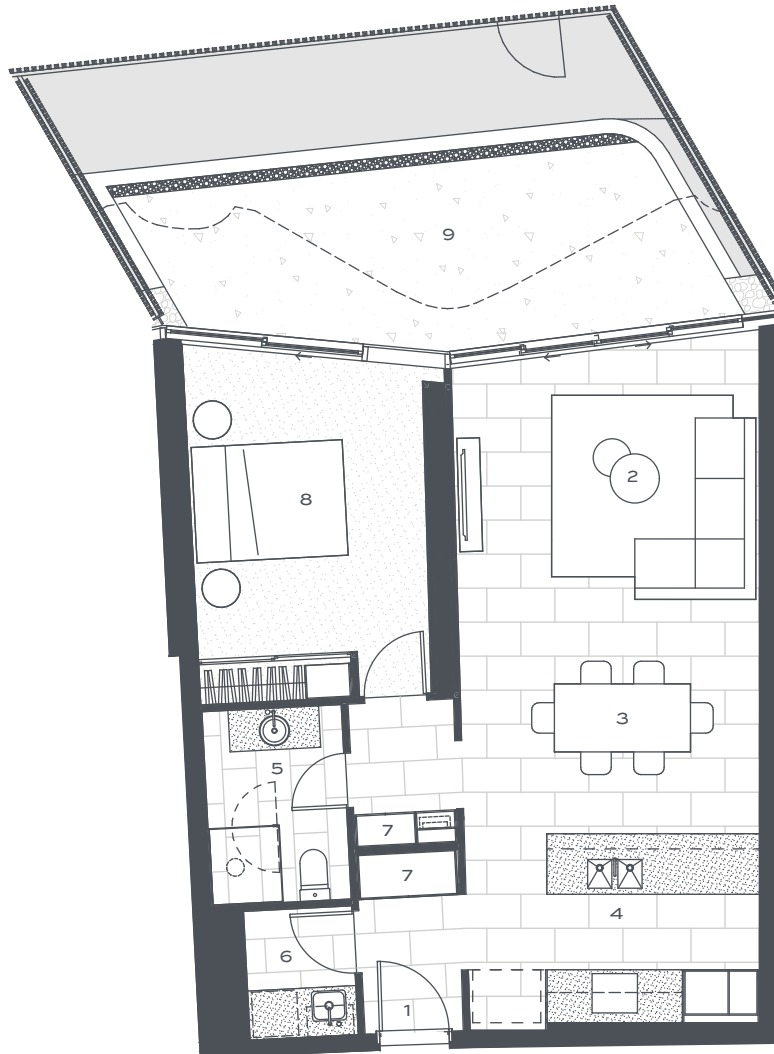



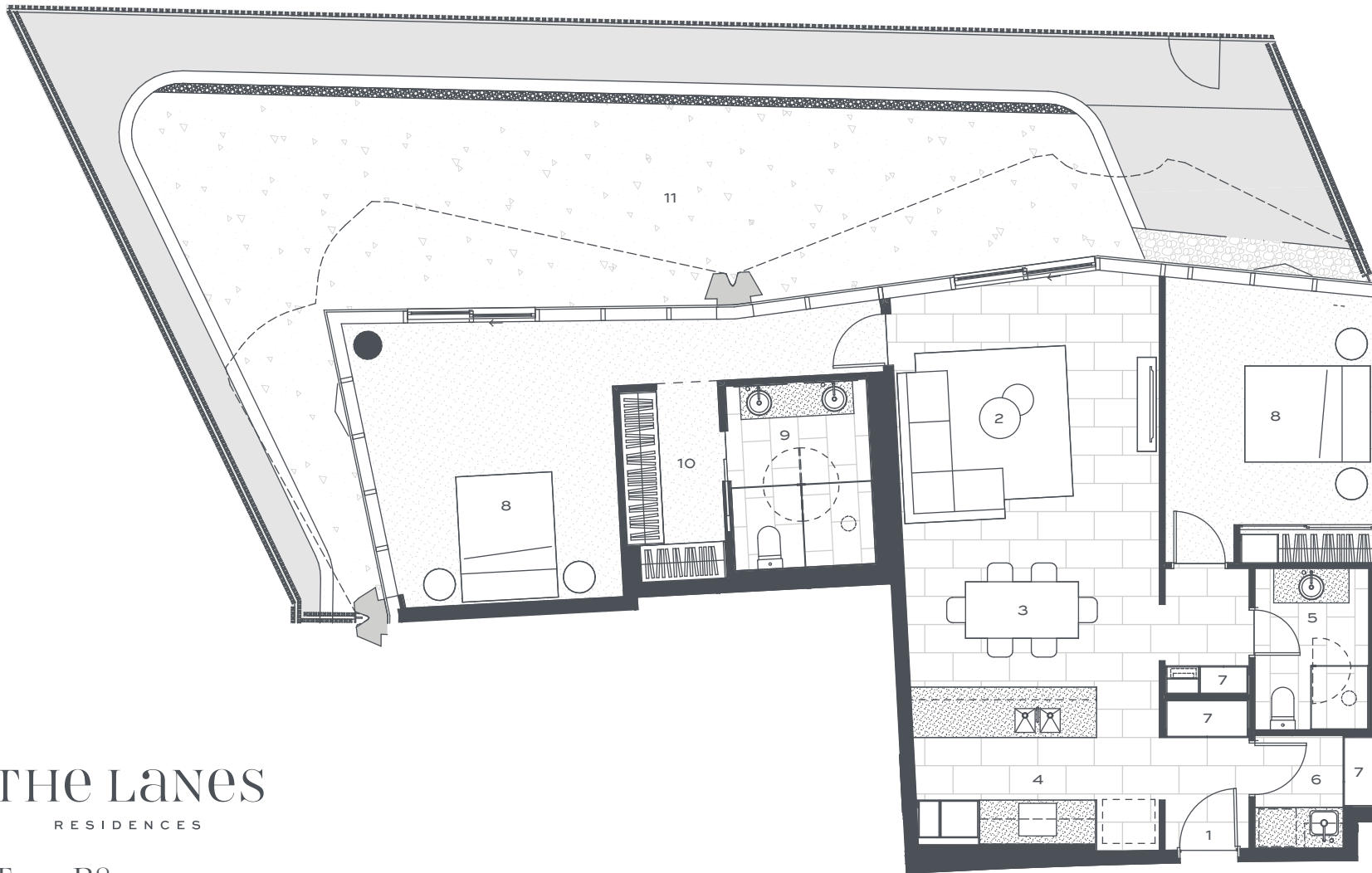

# THE LANES

RESIDENCES

## Type B8

LEVEL 1 GROUND

UNIT 4103

INTERNAL 110m<sup>2</sup>

EXTERNAL 59m<sup>2</sup>

TOTAL AREA 169m<sup>2</sup>

0m 4m



WEST VILLAGE KEY PLAN

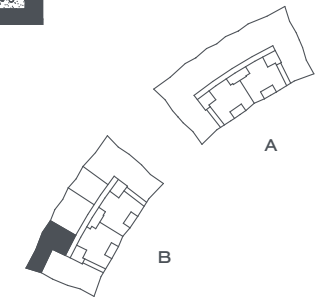

01 ENTRY 02 LIVING 03 DINING 04 KITCHEN 05 BATHROOM 06 LAUNDRY 07 LINEN 08 BEDROOM 09 ENSUITE 10 WALK-IN ROBE 11 COURTYARD

Indicative floor plan and artist impression only. Refer to the floor plans contained in the contract of sale for the actual floor plan as variations may apply. All floor areas measured to the centre of external walls and centre line of party walls. All external areas (patio and balconies) are included in the area calculation. External architectural features shown are indicative only. All reasonable care has been taken in the preparation of these floor plans. To the best of our knowledge, no relevant information has been omitted. However Sunland Group Limited and its appointed agents disclaim all liability should any information or matter contained herein differ from the contract of sale or the actual constructed development. Images are illustrative only and all information is correct at the time of printing. © Sunland Group Limited. All rights reserved.